

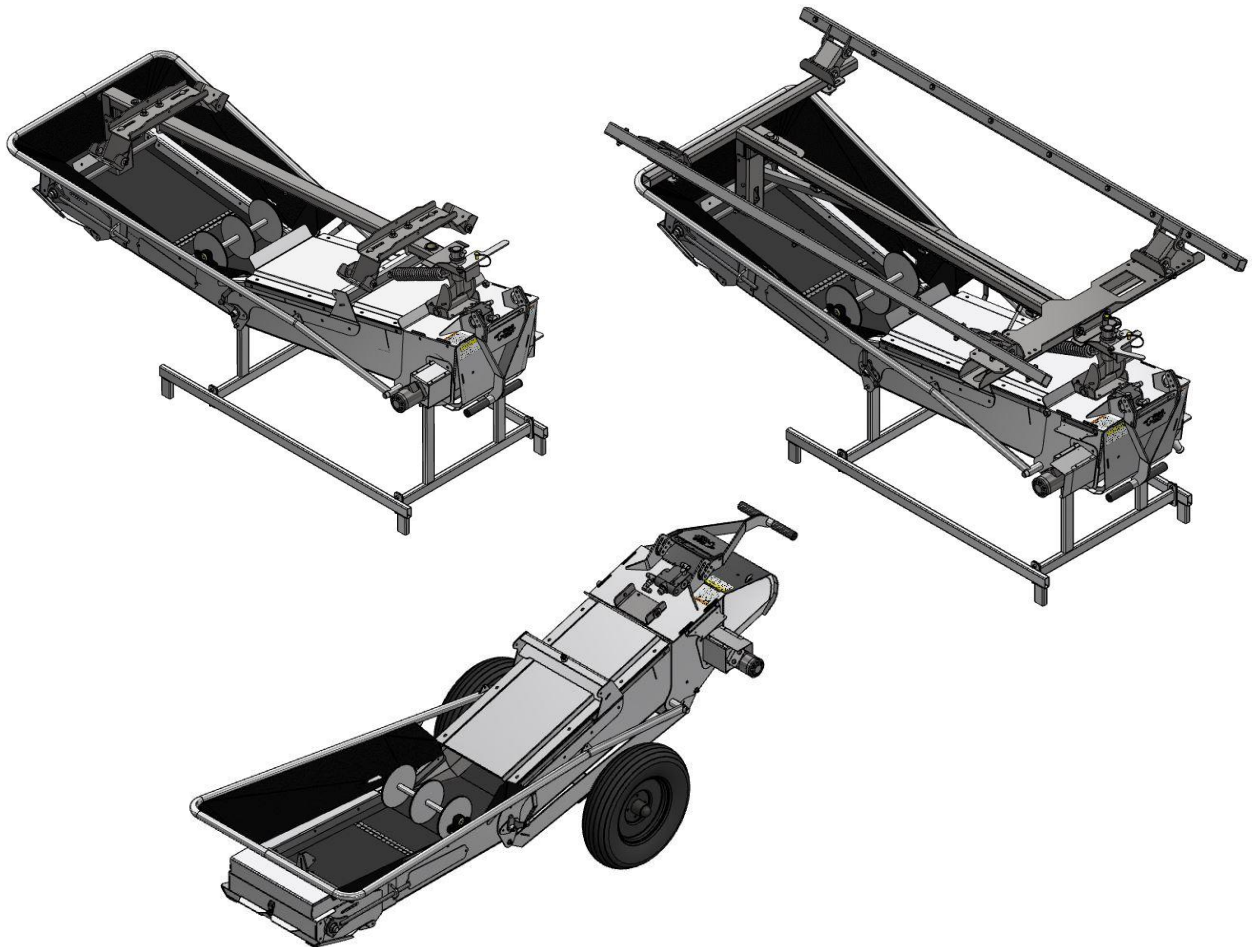

Operator and Parts Manual



**This manual applies to:
Swing Frame, Fixed Frame, and Portable Frame**



READ and UNDERSTAND all the Safety and Operation instructions contained in this manual before using this equipment. Failure to follow instructions and safety precautions can result in serious injury or death. Keep this manual where it is easily accessible for future reference.

Licensed under
Canadian Patent# 2,820,722
U.S. Patent # 8,992,156 B2

Table of Contents

1.0	Introduction	4
1.1	Using the Operator’s Manual.....	4
2.0	Safety	5
2.1	Recognize Safety Information	5
2.2	Understand Signal Words	5
2.3	General.....	5
2.4	Perform initial assembly safely	6
2.5	Operation Safety	6
2.6	Maintenance Safety	6
2.7	Storage Safety	6
2.8	Avoid High Pressure Fluids.....	6
2.9	Safety Decals	7
2.10	Decal Installation.....	7
2.11	Safety Decal Locations	7
3.0	Intended use of the Trailer Conveyor	8
4.0	Description and Types of Trailer Conveyor.....	8
4.1	Trailer Conveyor Types	8
5.0	Operation of the Convey Hawk.....	9
5.1	Operating the Convey Hawk II	9
5.2	Placing the Convey Hawk II in Storage/Transport Position	12
5.3	Removing the Convey Hawk II from the Semi-Trailer.....	14
5.4	Things to Watch For	15
6.0	Maintenance and Adjustments.....	20
6.1	Yearly Maintenance	20
6.2	Spring Tension Adjustment.....	20
6.3	Conveyor Belt Tension	21
7.0	Warranty	22

8.0	Parts Information	23
8.1	Convey Hawk II – Main Frame, Belt and Cover Plates	23
8.2	Convey Hawk II – Conveyor Pans	24
8.3	Convey Hawk II – Top Head.....	25
8.4	Convey Hawk II – Bottom End.....	26
8.5	Convey Hawk II – Hopper Components	27
8.6	Convey Hawk II – Lift Components	28
8.7	0013-001303 Universal Spring Package	29
8.8	0013-001307 Sub Frame Package	30
8.9	0013-000306 Swinging Trolley Assembly Package.....	31
8.10	0013-000004 Standard Manual Hydraulic Flow Control.....	32
8.11	0013-000002 - 200 Series Wireless Hydraulic Components	33
8.12	0013-000332 Standard Fixed Frame Mounting Kit	34
8.13	0013-000330 Standard Swing Frame Mounting Kit	34
8.14	0013-001200 Convey Hawk II Install/Storage Stand.....	35
8.15	0013-001400 - Convey Hawk II Portable Frame	36
8.16	Convey Hawk Options.....	36
9.0	Contact Us.....	36

1.0 Introduction

Congratulations. We are confident that your new “*Convey Hawk II*” **Trailer Conveyor** will provide you with years of safe, efficient, trouble free service.

Read and understand the **Warranty Policy** statement found in this manual.

To ensure continued safe and reliable operation of this equipment, use only **Michel’s Original Equipment Replacement Parts**. Use of unauthorized parts will void warranty.

Please fill out the ownership registration card as soon as possible.

Thank you.

1.1 Using the Operator’s Manual

Read this entire operator’s manual before using the ‘Convey Hawk II’.

- Anyone using this equipment must read this manual and all safety decals attached to the implement and familiarize themselves with the various features of the equipment and its safe operation.
- This manual should be considered an essential part of your machine and should remain with the machine when you sell it. Keep it in the tractor so that the operator or service personnel have immediate access to it.
- Immediately obtain a new operator’s manual if this manual is damaged or lost. It can be viewed and downloaded from the Michel’s website. www.michels.ca
- Measurements in this manual are provided in Imperial/US units. Use only correct replacement parts and fasteners.
- The manufacturer reserves the right to make changes to the design and specification of this machine and its components arising from further technical development. Illustrations and instructions in this manual are up to date at the time of publication.
- This manual and safety signs on your machine may also be available in other languages. (Contact Michel’s Ind.)
- If you have questions concerning this operator’s manual, contact Michel’s Ind..

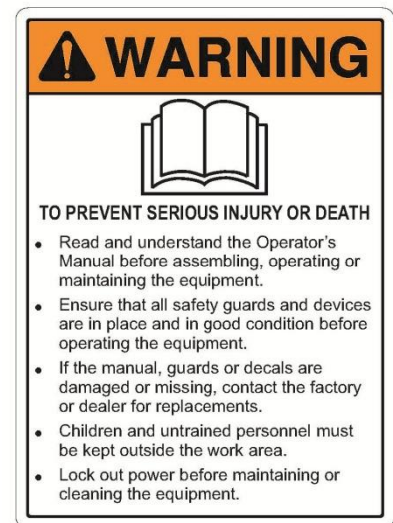

2.0 Safety

2.1 Recognize Safety Information



This is a safety-alert symbol. The safety-alert symbol combined with a signal word, is used throughout this manual and on decals which are attached to the equipment. The symbol and signal word are intended to warn the operator of impending hazards and the degree of possible injury faced when operating this equipment. Follow recommended precautions and safe operating practices.

2.2 Understand Signal Words

A signal word DANGER, WARNING, or CAUTION is used with the safety-alert symbol. The appropriate signal word for each message has been selected using the following definitions as a guide.

REF. ANSI Z535



Indicates a hazardous situation which, if not avoided, **will** result in serious injury or death.



Indicates a hazardous situation that, if not avoided, **could** result in serious injury or death.



Indicates a hazardous situation that, if not avoided, **may** result in minor or moderate injury.

2.3 General

The general safety section includes instructions that apply to all safety practices.

YOU are responsible for the SAFE use and maintenance of your equipment. YOU must ensure that you and anyone else who is going to work around the equipment understands all procedures and related SAFETY information contained in this manual. All accidents can be avoided.

- It is the equipment owner and the operator's responsibility to read and understand ALL safety instructions, safety decals, and manuals and follow them before assembling, operating, or maintaining the equipment.
- The equipment owner is responsible for providing instruction and training on the contents of this manual to personnel before allowing them to operate the equipment. An untrained operator may expose themselves and bystanders to possible serious injury or death.
- Use this equipment for its intended purposes only.
- Do not modify the equipment in any way. Unauthorized modification may impair the function and safe operation of the equipment and will void the warranty.
- Do not allow children, spectators, or bystanders within the work area.



2.4 Perform initial assembly safety

- During assembly, and adjustment procedures, it may be necessary to operate the trailer conveyor controls. Stay clear of machine elements during any operation of the hydraulics.
- Practice good communication with other service technicians. Be aware of their actions and alert them to potential hazards.

2.5 Operation Safety

- Have another person nearby who can shut down the equipment in case of an accident.
- Do not operate with any of the safety guards removed.
- Keep body, hair, and clothing away from moving parts. Stay away from intake during operation.

2.6 Maintenance Safety

- Before applying pressure to a hydraulic system, make sure all components are tight and that hoses and couplings are in good condition.
- After maintenance is complete, replace and secure all safety guards and safety devices.
- Remove all tools and unused parts from machine before operation.
- Inspect all parts. Ensure parts are in good condition and installed properly

2.7 Storage Safety

- Store in an area away from human activity.
- Do not permit children to play on or around the stored machine.

2.8 Avoid High Pressure Fluids



WARNING

Escaping fluid under pressure can penetrate the skin causing serious injury.

- Avoid the hazard by relieving pressure before disconnecting hydraulic or other lines. Tighten all connections before applying pressure. Search for leaks with a piece of cardboard. Protect hands and body from high pressure fluids.
- If an accident occurs, see a doctor immediately. Any fluid injected into the skin must be surgically removed within a few hours or gangrene may result.
- Hydraulic hoses can fail due to physical damage, kinks, age and exposure. Check hoses regularly. Replace damaged hoses.

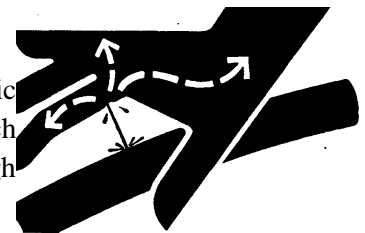

2.9 Safety Decals

- Keep safety decals clean and legible at all times.
- Replace safety decals that are missing or have become illegible. See decal location illustration below.
- Safety decals are available from your dealer, or the manufacturer.

2.10 Decal Installation

- Decal area must be clean and dry, with a temperature above 10°C (50°F).
- Decide on the exact position before you remove the backing paper.
- Align the decal over the specified area and carefully press the small portion with the exposed sticky backing in place.
- Slowly peel back the remaining paper and carefully smooth the remaining portion of the decal in place.
- Small air pockets can be pierced with a pin and smoothed out using the decal backing paper.

2.11 Safety Decal Locations

Illustrations of the safety decals that are attached to the equipment and their location on the equipment are shown below. Familiarize yourself with the safety decals and the safety precautions they describe, in order to avoid serious, injury, death, or damage to equipment.

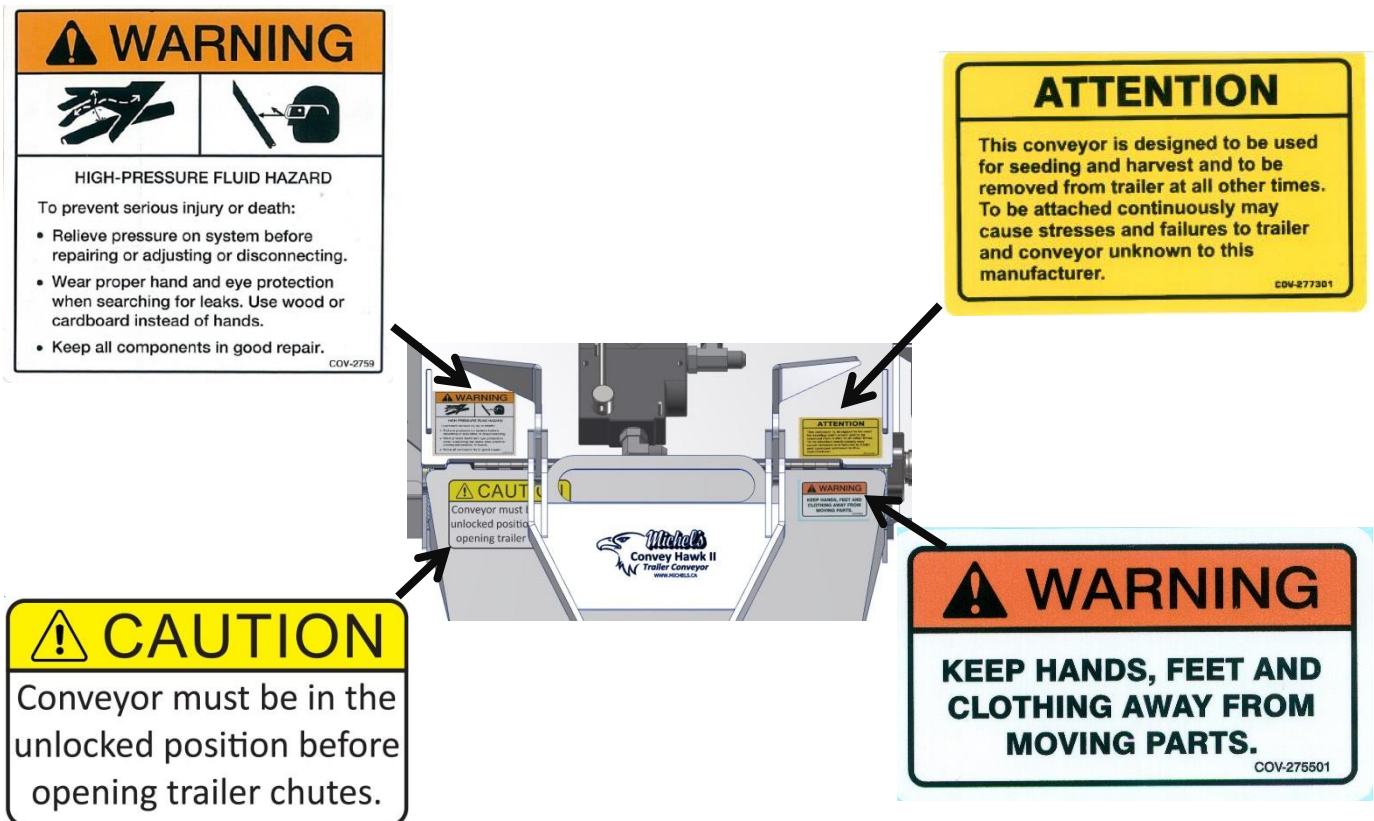

3.0 Intended use of the Trailer Conveyor

The trailer conveyor is used as a transfer conveyor for moving grain and/or fertilizer. The frame mounts between the two hoppers on semi-trailers used to haul grain or fertilizer. The conveyor swings down from the transport position and the hopper is placed under each semi-trailer chute opening. It then transfers the contents to the side central location so that it can unload into the hopper of an air seeder hopper.

It is mounted on the semi-trailer during the seeding season, and should be removed and stored when seeding season is over. Prolonged highway and road travel may cause undue stress and failure to the trailer and or conveyor mounts. Continually monitor the trailer and conveyor mounts for cracks, loose fasteners or other signs of fatigue!

Michel Industries Limited assumes no liability for damage or injury due to non-intended use. Non-intended use is any use not described above.

4.0 Description and Types of Trailer Conveyor

4.1 Trailer Conveyor Types

There are three different configurations:

1. Swinging Frame – Used on regular semi-trailers.



2. Fixed Frame – Used on Super-b semi-trailers

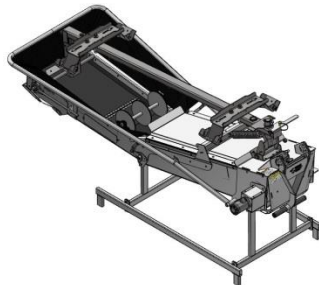

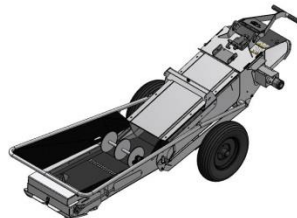

3. Portable – Used anywhere



5.0 Operation of the Convey Hawk

5.1 Operating the Convey Hawk II

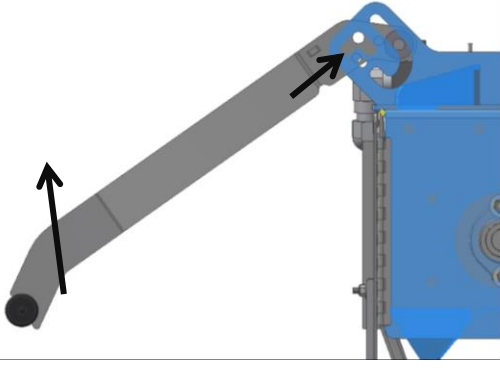
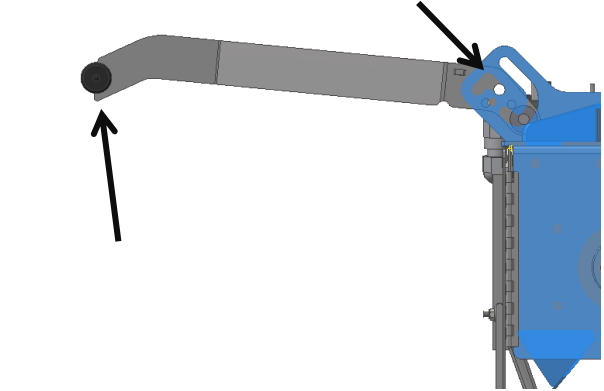
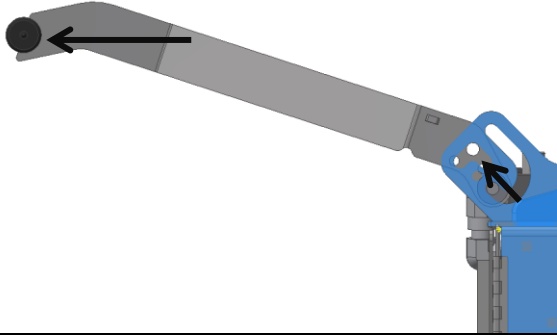
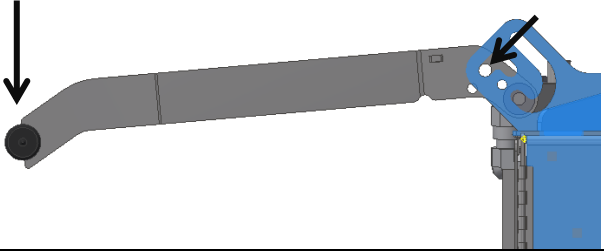
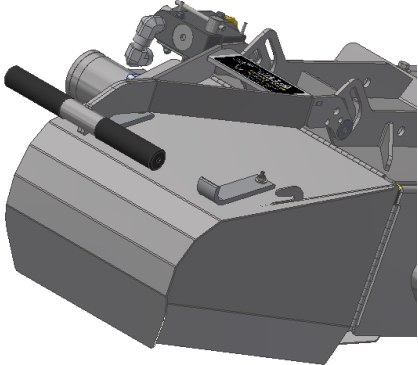
The Convey Hawk provides efficient transferring of grain or fertilizer from the chute of a semi-trailers. To operate, use the following steps:

Step 1 Lift up on the handle	Step 2 Push in and Lift up on the handle
	
Step 3 Pull up on the handle	Step 4 Push down on the handle
	
Step 5 Lift the Top Spout Panel and pull the Spout Side Panels out to the slots on the Top Spout Panel	Step 6 Push the plastic lock handles out until the Spout is tight.
	

Step 7

(Swinging frame only) Unlock the conveyor on the swing rail to swing forward or back. Keep the locking pin in your hand as you will need it momentarily.

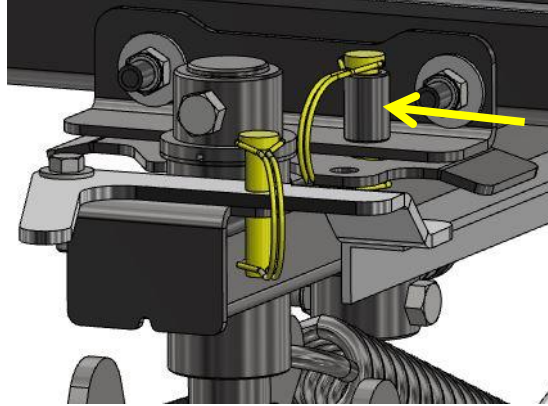

Step 8

(Swinging frame only) With both hands on the conveyor handle swing the conveyor to the front or rear of the swing frame.

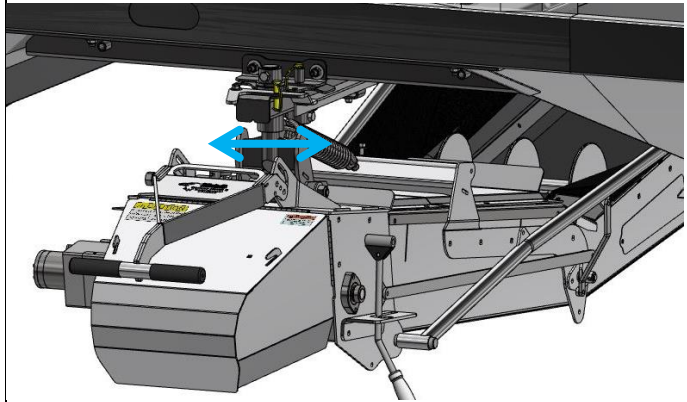

Step 9

Unlock the latch holding up the conveyor by removing the 1/2" pin (blue arrow). Temporarily relocate 1/2" pin to its storage hole (red arrow).

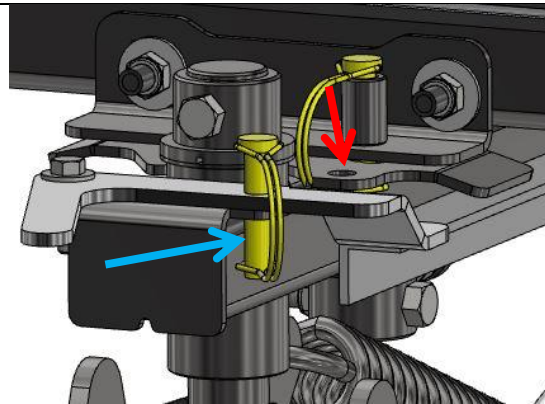

Step 10

While holding the conveyor handle down with your right hand (black arrow) pull the latch with your left hand (red arrow) to release the conveyor to drop.

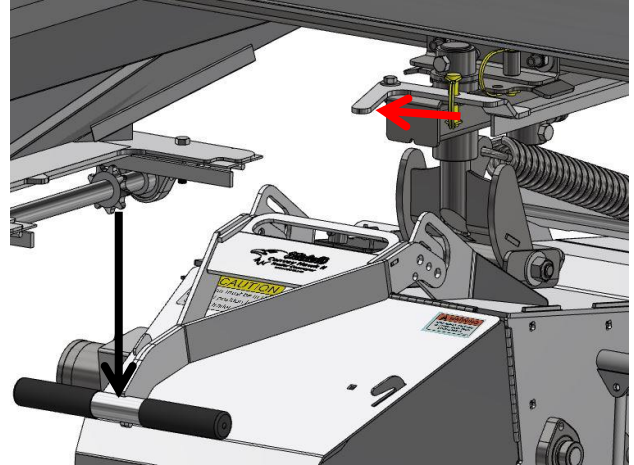

Step 11

When the conveyor drops, pivot under the hopper. If set properly the limit chain should stop the conveyor in the proper location. It may be that the conveyor will need to be moved slightly when completely emptying the hopper.

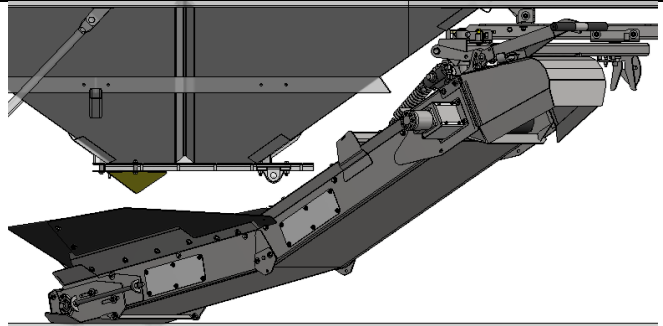

Step 12

By moving the arm on the flow valve the speed of the belt can be increased, decreased or stopped. It is recommended not to run the belt any faster than 560 feet per minute or 35 belt revolutions per minute. (Count the lacing passing by).



5.2 Placing the Convey Hawk II in Storage/Transport Position

To place the Convey Hawk into storage/transport position, use the following steps:

5.2.1

The Conveyor doesn't have to be 100% square to go up into position. The rear lock locator will help guide it into position.

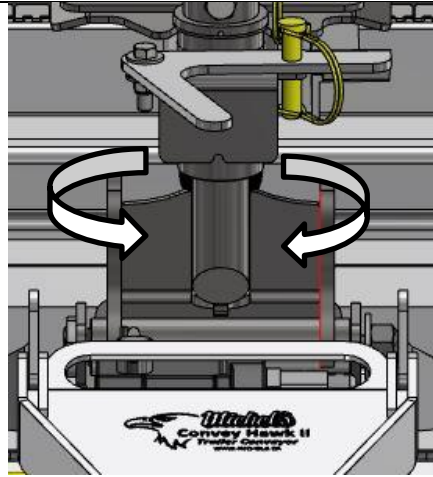
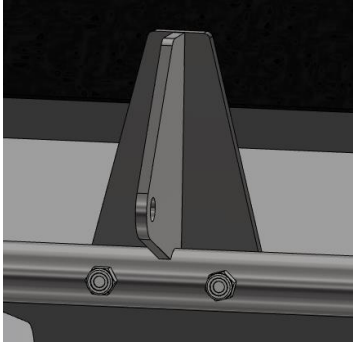

5.2.2

With the conveyor is lined up use both hands and push down until you hear and feel the conveyor latch engage. (Yellow arrow)

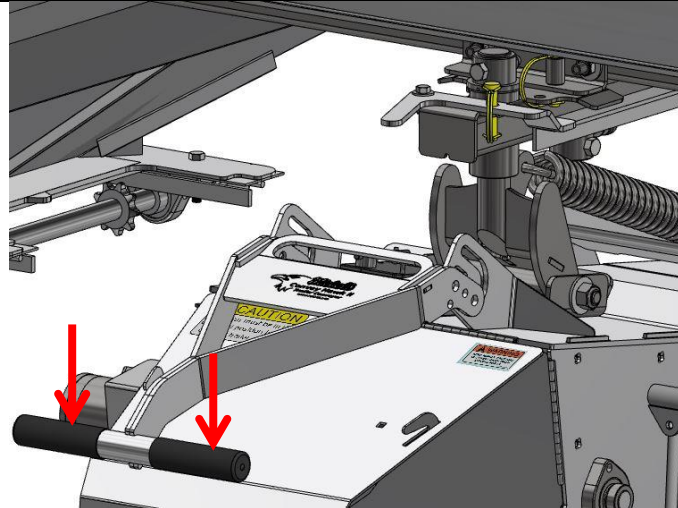
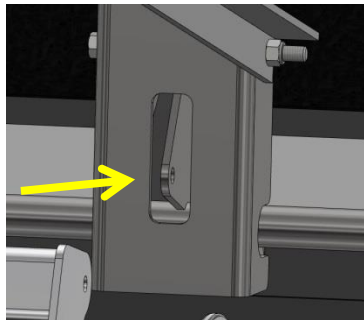

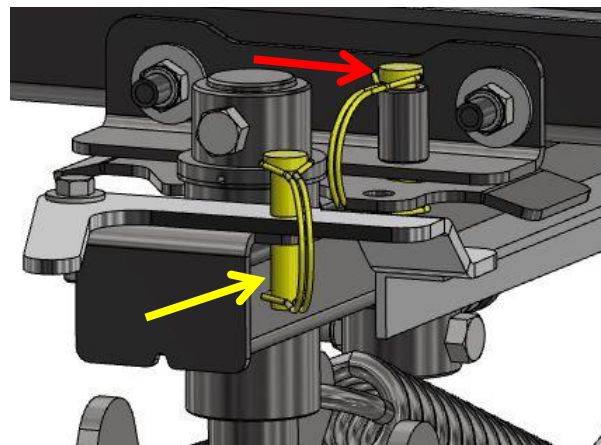

5.2.3

Once the conveyor is up in the transport position re-install both 1/2" lock pins in the latch (yellow) and the center of the swing rail (red).

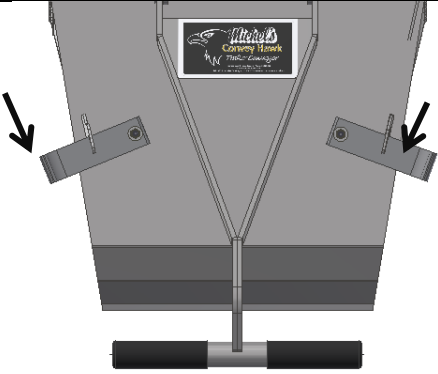
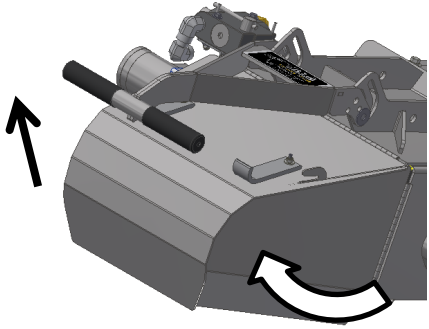
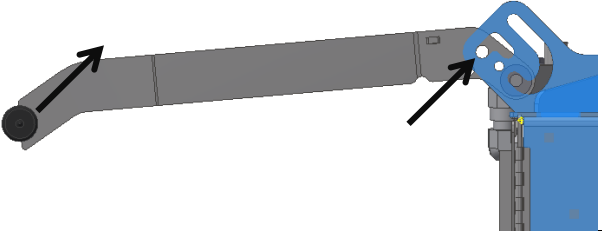
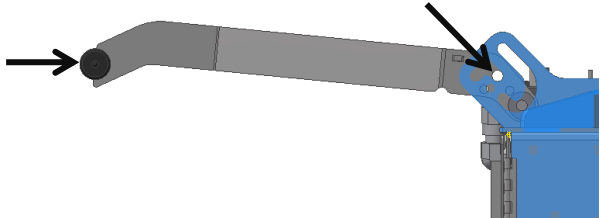
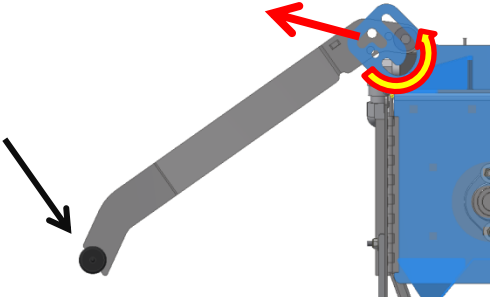

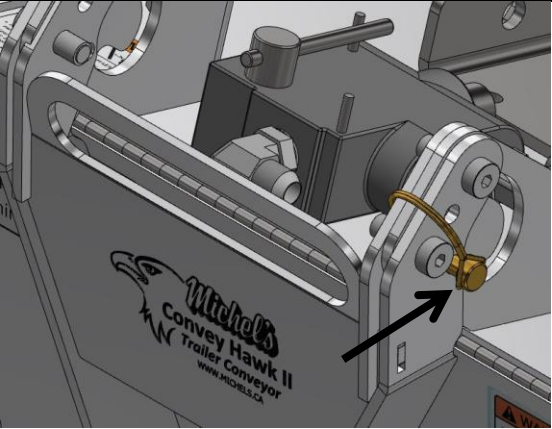
<p>5.2.4 Push the plastic lock handles towards the center until the Spout is unlocked.</p>	
<p>5.2.5 Lift the Top Spout Panel (Black arrow) and fold the Spout Side Panels in. (White/Black Arrow)</p>	
<p>5.2.6 Pull up on the handle.</p>	
<p>5.2.7 Push in and down on the handle.</p>	
<p>5.2.8 Pull up on the Hand Hole (Red Arrow) and push down on the handle. (Black Arrow)</p>	

<p>5.2.9 Once the Spout and Handle are in the transport position, insert the quick pin to lock the handle.</p>	
<p>5.2.10 As a double safety measure. Install the quick pin into the rear latch plate in the Intake Hopper.</p>	

5.3 Removing the Convey Hawk II from the Semi-Trailer

When not being used, the Convey Hawk II should be removed from the semi-trailer. One benefit is it will reduce the weight of the trailer. Another benefit is it will prevent the Convey Hawk II from damage while travelling down the highways and roads, minimizing stone chips and dust. To remove the Convey Hawk II from the semi-trailer, follow these steps:

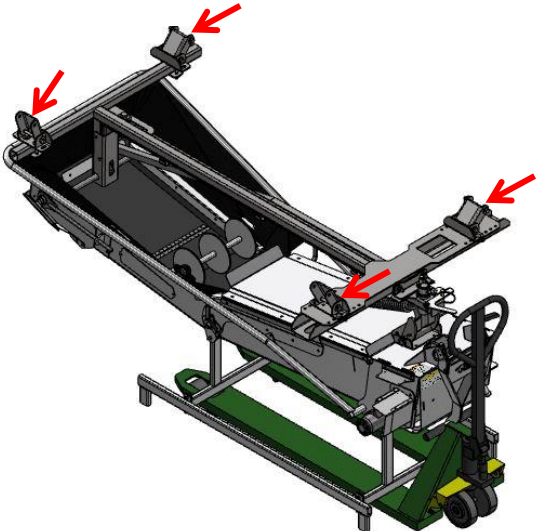
<ol style="list-style-type: none">1. Park the semi-trailer on a concrete pad.2. Place the storage frame under the Convey Hawk II, using a pallet jack, lift the storage frame into position and bolt it in position.3. Remove the bolts on all 4 corners from the trailer mounting base plates or tubing's. (Red Arrows)4. Lower the pallet jack enough to clear the semi-trailer and roll the conveyor out of the way.5. Place the Convey Hawk in a storage location such as inside a building. Cover with a tarp if desired.	
--	--

5.4 Things to Watch For

Some handy tips on how to use your Trailer Conveyor in the most efficient way:

Warning: On some trailers (Mostly Super-B's) it is not possible to open the slides while the conveyor is in the transport position. To unload you will be required to lower the conveyor and pivot it out of the way.

Remote openers will cause damage!

Note: Neither of the chutes will open all of the way and will contact the Convey Hawk II.

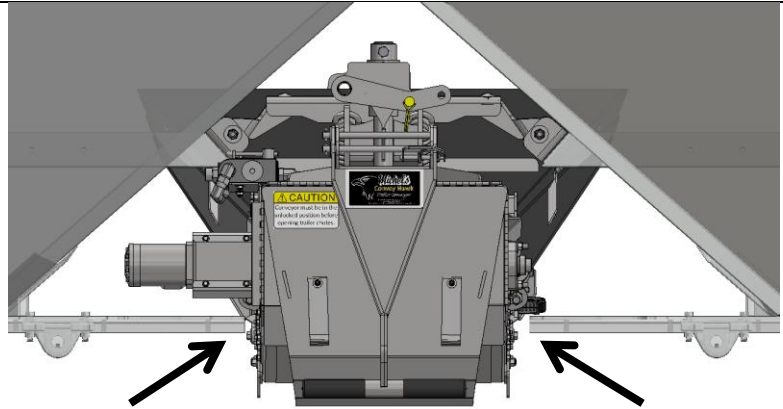



At times the limit chain will tangle up and reduce the amount of pivot travel the conveyor will have. Pivot the conveyor back to the center and un-tangle.

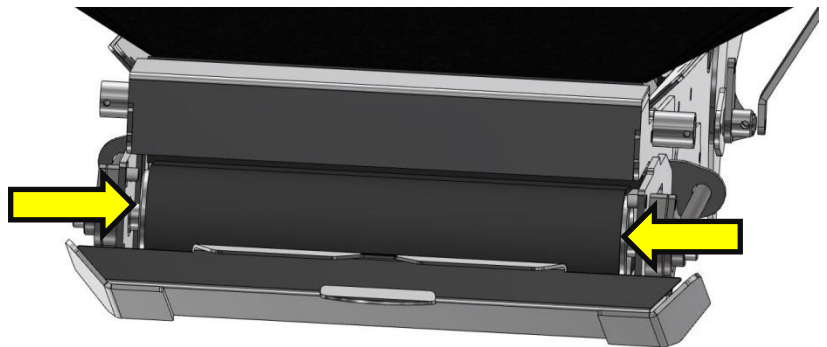

When using the conveyor for the first time, make sure that the belt continues to track in the center of the rollers. The rear cover can be removed to make this easier to see. The conveyor is pre-run at the factory but a new belt may wander. Periodically check the tracking of the belt and adjust when needed.

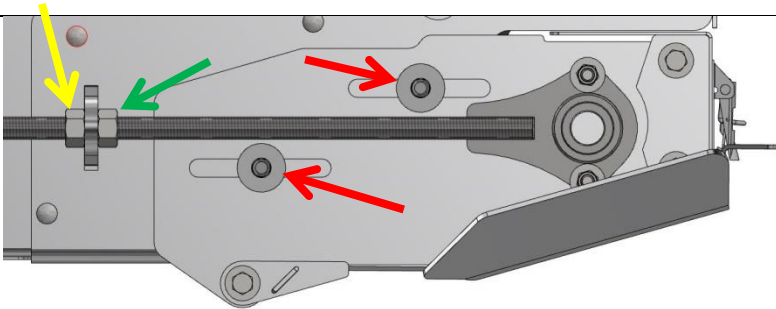
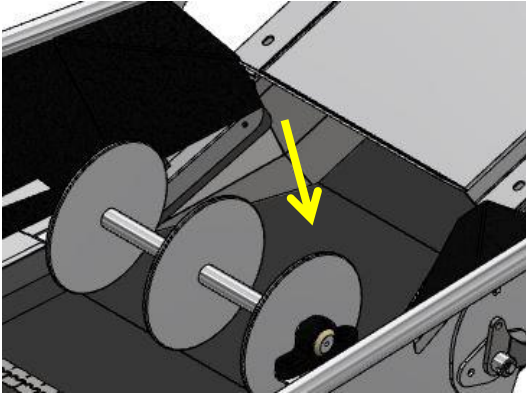

<p>To adjust the roller loosen the 1/2" nuts (red arrows) and loosen the 5/8" nut (yellow arrow) and adjust the other 5/8" nut (green arrow) to tighten the roller and belt. This needs to be adjusted on both sides evenly.</p>	 A side-view technical drawing of a roller assembly. A horizontal shaft passes through several rollers. A yellow arrow points to a 5/8" nut on the left side of the shaft. A green arrow points to a 5/8" nut on the right side of the shaft. Two red arrows point to 1/2" nuts on the right side of the shaft, one above and one below the main roller.
<p>Adjust the bottom roller to where the belt begins to lift in the center above the three idler rollers. There should be belt tension on the rollers.</p>	 A perspective view of a belt running over three idler rollers. A yellow arrow points to the bottom roller, indicating the adjustment point for belt tension.
<p>For initial settings use a tape measure and measure from the adjusting tab (red arrow) to the conveyor frame (yellow arrow). You will still have to fine tune the adjustments to get the belt to track just right. When the correct tension is found, re-tighten the locking nuts on the adjustment All-thread rods. Lift up on the back of the conveyor (Black Arrow) and tighten the 1/2" carriage bolts on the bearing holders.</p>	 A side-view technical drawing of a roller assembly. A red arrow points to an adjusting tab on the left. A yellow arrow points to the conveyor frame on the left. A black arrow points upwards from the bottom right corner of the assembly.

Before putting the conveyor away for the year it should be washed out. It is recommended that the tarp be removed and cleaned out underneath the transfer belt.

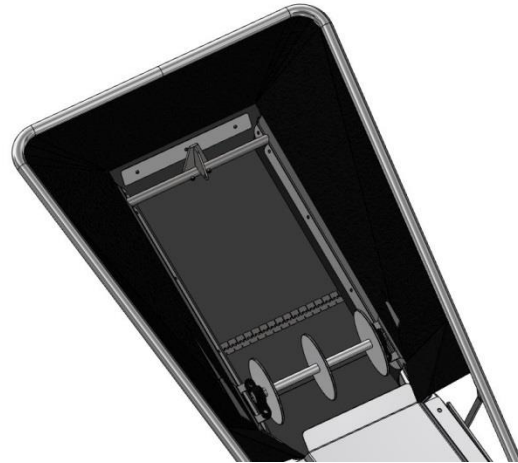

Due to the design of the conveyor you will see some of the chevrons on the transfer belt wear off in this area. This is normal and actually creates a better seal with the side belts. If a groove begins to form in the belt there may be a roller fender problem. This belt has moved 30,000 bushels.



There is a trap door at the bottom of the conveyor to clean out any grain that has made its way all the way around. The hole in the trap door is for pouring the grain through into a 5 gallon pail. Remove both side panels to gain access to the inside of the belt. Either use compressed air to blow the excess product out or use a vacuum cleaner to suck the product out. Use **CAUTION** if cleaning the conveyor out if the belt is turning.

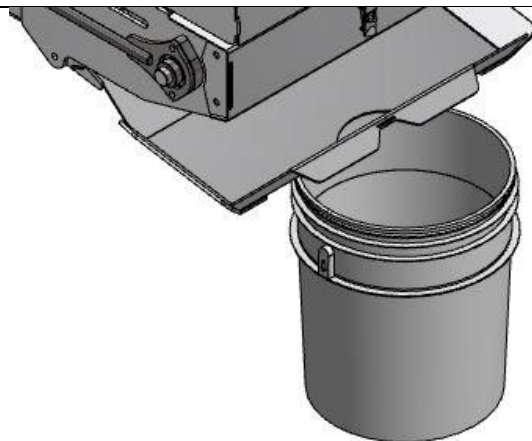

The conveyors that require a swinging frame may need to have the track cleaned of small gravel stones and dirt periodically.

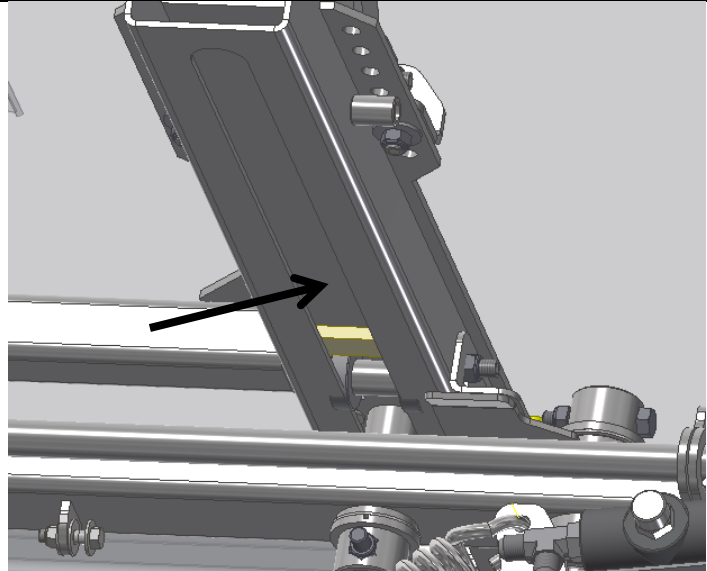

The stabilizer plate on the swinging frame keeps the conveyor from rocking when it transport. Make sure that the plate (Yellow Arrow) remains tight with the top plate of the sub-frame (Red Arrow).

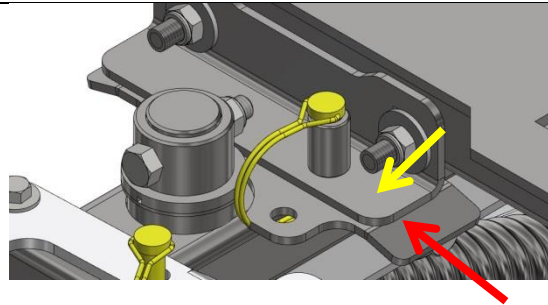

The spring should hold the conveyor just above the ground in the down position. It works best to use a ratchet (Black Arrow) and a 15/16" socket to adjust.

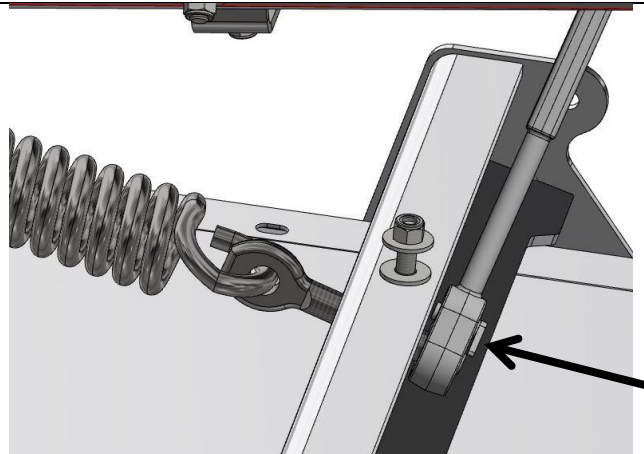

If it happens that product gets under the belt and between the roller and belt, the belt will rise up in the center. If not corrected the lacing can catch on the splash plate as shown. (Yellow Arrow)



Watch for stress points showing up, cracked welds, etc. in the swinging frame, mounting brackets or conveyor. Fix and repair any fatigue areas immediately. A conveyor falling off a trailer is extremely dangerous in traffic!!!!

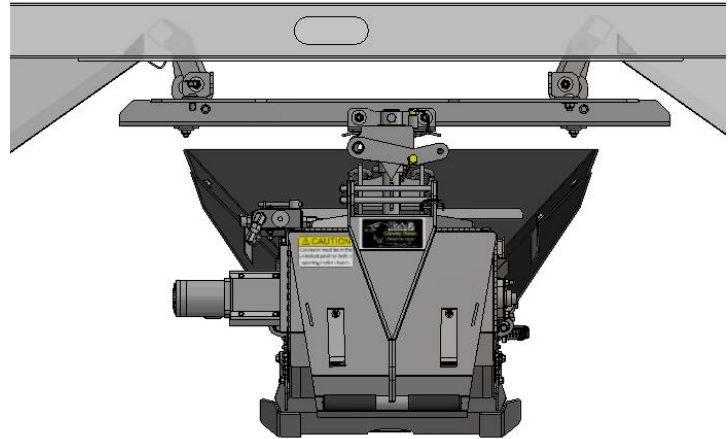

The conveyor and mounting brackets are designed and built for agricultural on farm use only. Continuous highway and road travel may eventually cause structural fatigue issues for the trailer and or conveyor. Remove from trailer when not needed.



When filling the conveyor start out by filling it slowly and then slowly increase the product flow to it. Over filling the conveyor too quickly at the start will cause the belt to lift at the bend and may plug. The conveyor requires the weight of the product on it to hold it in place and work properly. Fill the conveyor until the product is at the idler wheels cross shaft.



Figure 1. Start to fill conveyor slowly

6.0 Maintenance and Adjustments

The maintenance required on the trailer conveyor is very minimal. However, it must be inspected at regular intervals to check for metal fatigue, loose bolts, oil leaks, wearing hydraulic hoses and the like. Any signs of fatigue or damage to the conveyor must be repaired immediately before being used again.

6.1 Yearly Maintenance

At the end of the season when the conveyor is removed from the trailer for storage, it should be washed down using a water spray. When the trailer is dry, use touch-up paint to repair any surfaces that have been worn out due to stone or rock chips. A high gloss black aerosol can from a hardware store will work.

6.2 Spring Tension Adjustment

As required, adjust the spring tension equally so that the conveyor remains slightly above the ground when empty.

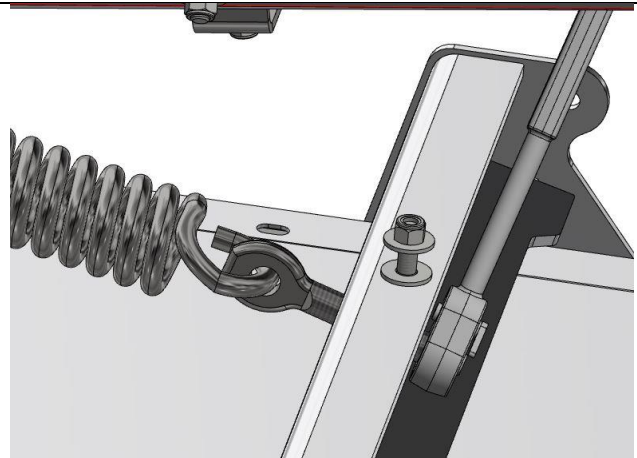

6.3 Conveyor Belt Tension

As required, adjust the conveyor belt tension. The tension of the belt is to be adjusted at the bottom of the conveyor. Adjusting the belt tension will increase or decrease the traction between the belt and drive roller. The left and right side tension adjustments (All-thread rod) will control the tracking of the belt. If the belt runs to the right either tighten the right side adjustment or loosen the left. When loosening a side adjustment, thread the front nut (Yellow Arrow) tighter. This will pull the bear and roller looser. The side adjustments push and pull depending on which nut is turned. To adjust the roller loosen the 1/2" nuts (red arrows) and loosen the 5/8" nut (yellow arrow) and adjust the other 5/8" nut (green arrow) to tighten the roller and belt. This needs to be adjusted on both sides evenly. Verify that the belt runs in the center of the back roller.

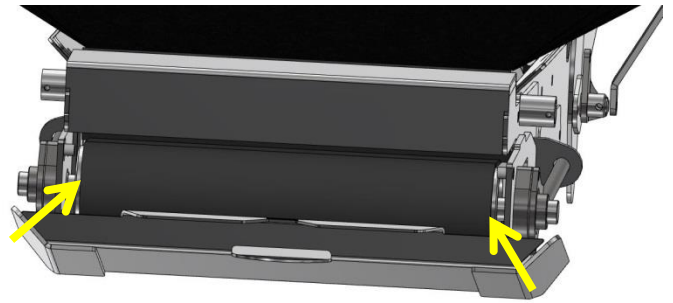
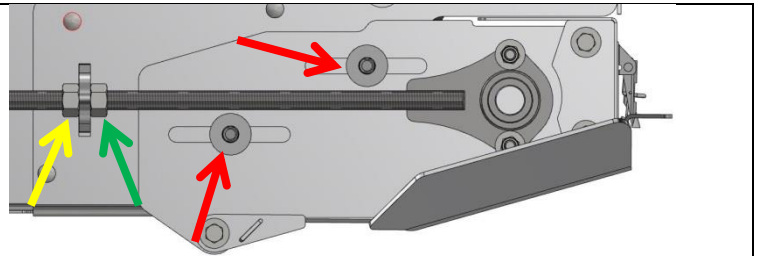

Adjust the bottom roller to where the belt begins to lift in the center at the bend and try it there.



For initial settings use a tape measure and measure from the adjusting tab (red arrow) to the conveyor frame (yellow arrow). You will still have to fine tune the adjustments to get the belt to track just right. When the correct tension is found, re-tighten the locking nuts on the adjustment All-thread rods. Lift up on the back of the conveyor (Black Arrow) and tighten the 1/2" carriage bolts on the bearing holders.



7.0 Warranty

Warranty Policy for CONVEY HAWK II and accessories

Michel's Industries, Ltd. ("the manufacturer") warrants to the original purchaser only, that in the event of any defect in material or workmanship in the CONVEY HAWK II, the subject of this warranty ("the goods") during the warranty period mentioned below, the manufacturer will provide the cover specified below.

This warranty is in place of any other warranty or guarantee whether implied or expressed in any conditions of purchase of the buyer, and does not extend to impose any further liability on the manufacturer than set out below.

CONDITIONS

1. This warranty does not extend to:
 - a. Damage or deterioration after delivery from the manufacturer's works not attributable to defective material or workmanship.
 - b. Any goods after they have been altered or repaired other than by the manufacturer's employees or its' agents in each case authorized in writing by the manufacturer to effect that specific alteration or repair to those specific goods.
 - c. Any equipment or machinery of any kind furnished by the buyer, or belonging to, or acquired from third parties at the buyer's request.
 - d. Any goods which have sustained damage or deterioration attributable to inadequate or faulty assembly.
2. This warranty is conditional upon:
 - a. Operation in accordance with the manufacturer's specifications and recommendations (as set out, or referred to in the 'manual') supplied for the goods.
 - b. Notifying the manufacturer within thirty (30) days of the time a part is discovered to be damaged or defective.
 - c. Examination of the goods by the manufacturer or one of its agents to verify that the goods are defective in material or workmanship.

COVER

1. In respect of claims notified:
 - a. Non-commercial or farm use - During the first twelve (12) months, parts and labour on repair.
 - b. Commercial use - During the first six (6) months, parts and labour on repair.
2. The buyer is responsible for any labour charges exceeding the quoted/pre-approved amount, as determined by Michel's Industries, Ltd. and for returning the goods to the dealer, whether or not the claim is approved. The buyer is responsible for the transportation costs of the goods or part(s) from the dealer to the designated factory.

WARRANTY PERIOD

1. Non-commercial or farm use - The warranty period shall be the period of twelve (12) months from the date of purchase.
2. Commercial use - The warranty period shall be the period of six (6) months from the date of purchase.

3. All notices and correspondence to the manufacturer shall be confirmed by letter addressed to:

Attention: Warranty Compliance
Michel's Industries, Ltd.
 Box 119
 St. Gregor, SK
 Canada, S0K 3X0

8.0 Parts Information

8.1 Convey Hawk II – Main Frame, Belt and Cover Plates

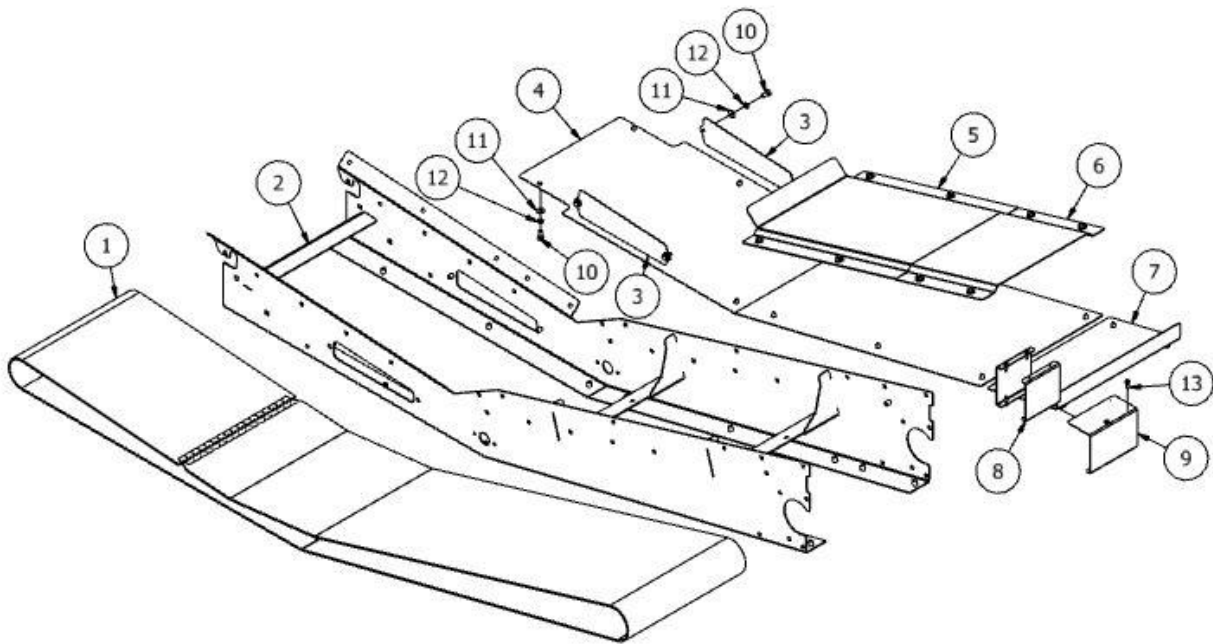

#	PART NUMBER	DESCRIPTION
1	0149-400001	Conveyor Belting 17.5" x 192" Laced w /RS125 PVC 120 Eclipse
2	0013-001001	Aluminum Main Frame - Weldment
3	0013-001012E	Clean Out Cover
4	0013-001035A	Large Bottom Cover
5	0013-001012A	Top Cover Bottom Piece
6	0013-001012B	Top Cover Top Piece
7	0013-001012C	Small Bottom Cover
8	0013-001012F	Coupler Box Cover
9	0013-001012FW	Coupler Box Cover Wireless System
10	0105-000201	3/8"-16x3/4"GR5 Hex Cap Screw
11	0101-001001	5/16" USS Flat Washer
12	0101-001202	3/8" Lock Washer
13	0106-000005	1/4" x 1" Lag Screw

8.2 Convey Hawk II – Conveyor Pans

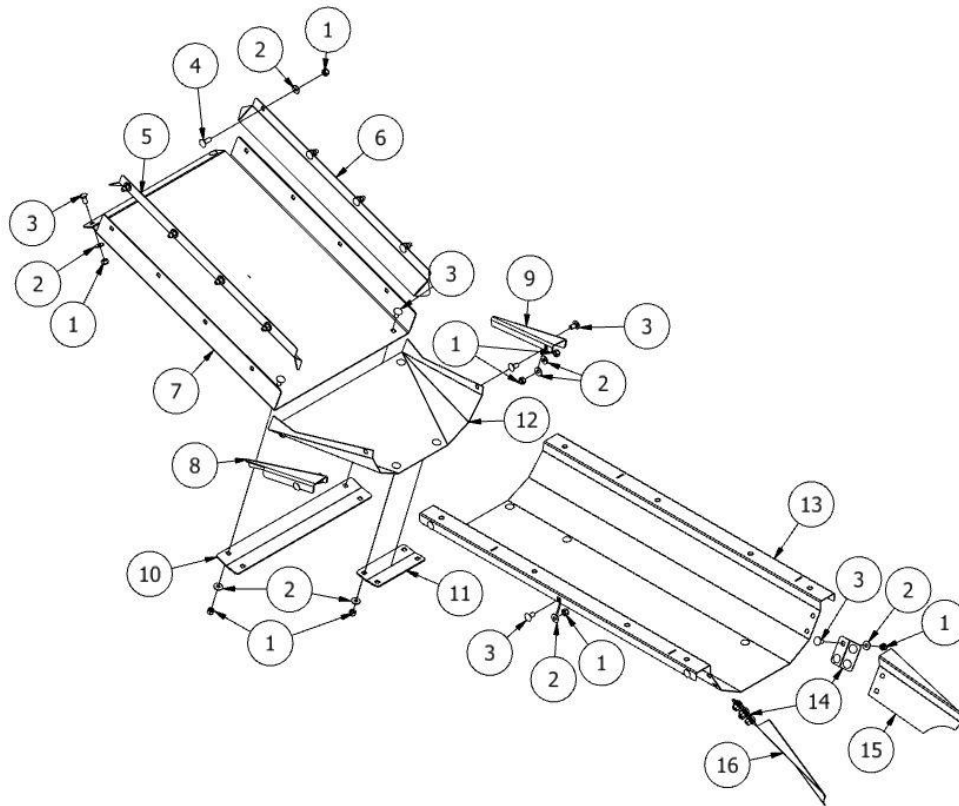

#	PART NUMBER	DESCRIPTION
1	0100-001102	3/8" Nylok Hex Nut
2	0101-001001	5/16" USS Flat Washer
3	0105-009216	3/8" x 3/4" Carriage Bolt PLTD
4	0105-009215	3/8" x 1" Carriage Head Bolt
5	0013-001002J	Bottom Belt Trough Side Guide Plate_MIR
6	0013-001002B	Bottom Belt Trough Side Guide Plate
7	0013-001002A	Bottom End Belt Trough
8	0013-001002I	Front Side Filler_MIR
9	0013-001002H	Rear Side Filler
10	0013-001002K	Middle Trough Support Bracket
11	0013-001002F	Middle and Bottom Trough Bracket
12	0013-001002L	Bottom Upper Belt Trough
13	0013-001002C	Middle Belt Trough
14	0013-001002G	Top and MiddleTrough Bracket
15	0013-001002E	Top Front Inside Belt Guide
16	0013-001002D	Top Front Inside Belt Trough

8.3 Convey Hawk II – Top Head

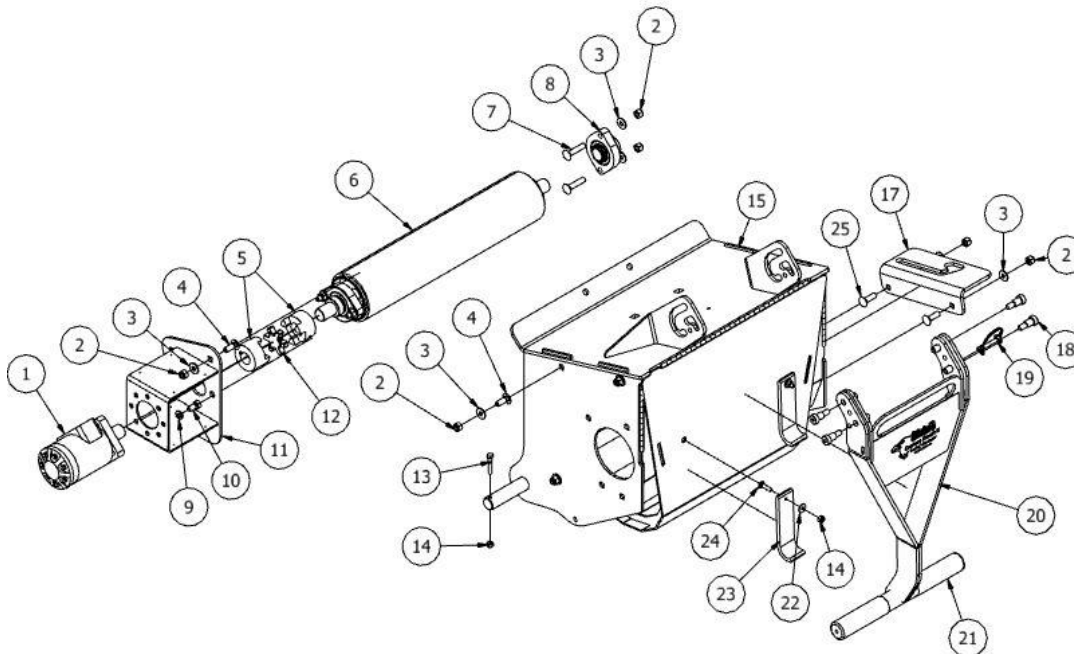

#	PART NUMBER	DESCRIPTION
1	0146-900002	Hyd Motor 101-1002-009
2	0100-001102	3/8" Nylok Hex Nut
3	0101-001001	5/16" USS Flat Washer
4	0105-009215	3/8"x 1 Carriage Bolt PLTD
5	0146-900001	1" Jaw Coupler
6	0013-001016CHEV	Drive Roller with Belting Complete Assembly
7	0105-009209	3/8" x 1-3/4" Carriage Head Full Thread Bolt
8	0115-000017	1" Bearing with 2 Bolt Housing Assembly
9	0101-001202	3/8" Lock Washer
10	0105-000201	3/8"-16x3/4"GR5 Hex Cap Screw
11	0013-001017	Lovejoy Motor Mount
12	0146-900006	Rubber Spider for 1" Jaw Coupler
13	0105-000005	1/4" x 1-1/2" Hex Bolt
14	0100-001100	1/4" Nylock Nut
15	0013-001003	Aluminum Top Head Assembly
16	0105-009203	3/8-16 UNC - 1.25 Carriage Bolt
17	0013-001023	Hopper Handle Lock Bracket
18	0105-006403	0.375 Thread x 0.5 Shoulder Bolt x 0.625 Long - Hex Socket
19	0110-000032	3/8" x 1-1/2" Quick Pin
20	0013-001013	Handle Assembly Aluminum
21	0113-000073	Black Vinyl Cap For Handle
22	0101-001000	1/4" USS Flat Washer
23	0013-000131	CH18 Spout Lock Handle
24	0105-009003	1/4"-20x1" Carriage Bolt
25	0105-009203	3/8-16 UNC - 1.25 Carriage Bolt

8.4 Convey Hawk II – Bottom End

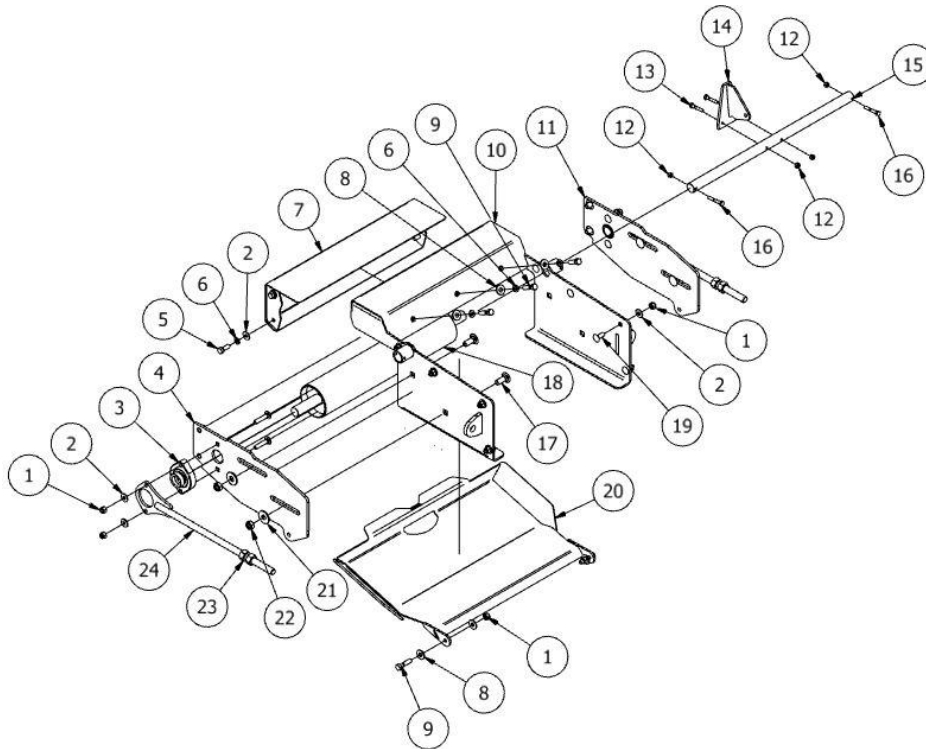

#	PART NUMBER	DESCRIPTION
1	0100-001102	3/8" Nylok Hex Nut
2	0101-001001	5/16" USS Flat Washer
3	0115-000017	1" Bearing with 2 Bolt Housing Assembly
4	0013-001031	Belt Tentioner Guide Plate Assembly MIR
5	0105-000202	3/8" x 1" NC Hex Bolt
6	0101-001202	3/8" Lock Washer
7	0013-001010	Bottom End Cover
8	0101-001002	3/8" USS Flat Washer
9	0105-000204	3/8" x 1-1/2" NC Hex Bolt
10	0013-001005	Bottom Frame Assembly
11	0013-001030	Belt Tentioner Guide Plate Assembly
12	0100-001100	1/4" Nylock Nut
13	0105-000005	1/4" x 1-1/2" Hex Bolt
14	0013-001014B	Lock Guide Upright Stainless Steel
15	0013-001014A	Lock Cross Shaft
16	0105-000006	1/4" x 1-3/4" Hex Bolt
17	0105-009417	1/2" x 1 1/4" Carriage Head GR5 Hex Cap Screw
18	0013-001015	Idler Roller Aluminum Assembly
19	0105-009215	3/8" x 1" Carriage Head Bolt
20	0013-001032	Clean Out Door
21	0101-001004	1/2" USS Flat Washer
22	0100-001104	1/2 NC Nylok Hex Nut
23	0100-001005	5/8" Hex Nut
24	0013-001008	Belt Tensioner

8.5 Convey Hawk II – Hopper Components

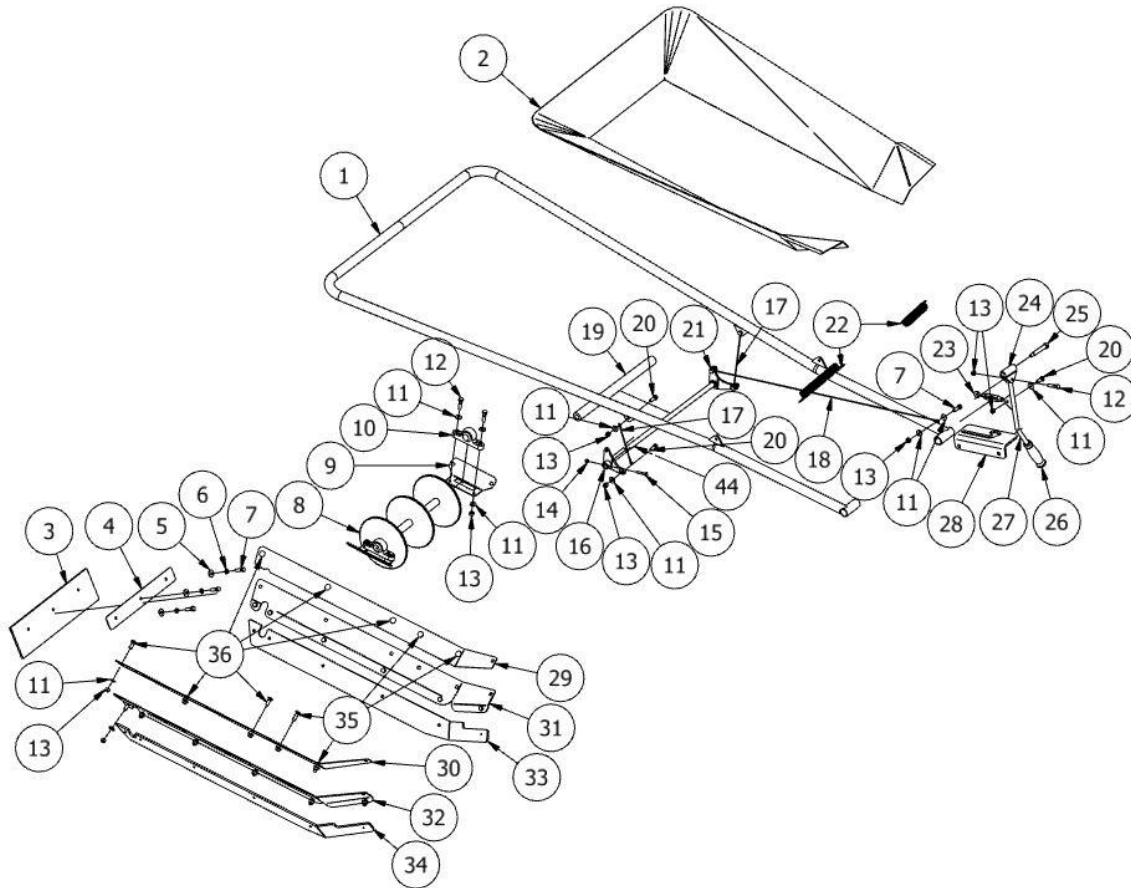

#	PART NUMBER	DESCRIPTION	#	PART NUMBER	DESCRIPTION
1	0013-001018	Hopper Intake Tubing Assembly c/w both sides	19	0013-000130	Bottom Belt Idler Roller1-1/4OD x 3/4" ID Nylatron
2	0013-001011K	Conveyor Hopper Sewn Tarp	20	0105-000202	3/8" x 1" NC Hex Bolt
3	0013-001011G	Passenger Side Hopper Belting Seal	21	0013-001021	Rear Hopper Link Arm
4	0013-001011H	Hopper Tarp Insert Small Panel	22	0117-004001	0.128 wire x 1.14OD x 6.75 Inside Hooks
5	0101-001002	3/8" USS Flat Washer	23	0112-000305	Turnbuckle C/W extra Nut
6	0101-001202	3/8" Lock Washer	24	0013-001024	Hopper Control Round Handle Pivot
7	0105-000203	3/8" x 1-1/4" NC Hex Bolt	25	0105-006404	0.375 Thread x 0.5 Shoulder Bolt x 0.625 Long - Hex Socket
8	0013-001011	Idler Wheel Assembly	26	0113-000015	Black Crank Grip - Small
9	0013-001011B	Idler Bearing Hopper Mounting Plate	27	0013-001025	Hopper Control Round Handle Main Shaft
10	0115-004006	Pillow Block & Bearing Unit - Low Profile	28	0013-001023	Hopper Handle Lock Bracket
11	0101-001001	5/16" USS Flat Washer	29	0013-001011I	Rear Hopper Insert Panel
12	0105-000204	3/8" x 1-1/2" NC Hex Bolt	30	0013-001011J	Front Hopper Insert Panel_MIR
13	0100-001102	3/8" Nylok Hex Nut	31	0013-001011C	Rear Hopper Inside Panel
14	0100-001100	1/4" Nylock Nut	32	0013-001011D	Front Hopper Inside Panel_MIR
15	0105-000005	1/4" x 1-1/2" Hex Bolt	33	0013-001011E	Rear Hopper Belting Seal Strip Seal
16	0013-001022	Front Hopper Link Arm	34	0013-001011F	Front Hopper Belting Seal Strip_MIR
17	0013-001028	Short Link Cable	35	0105-009203	3/8-16 UNC - 1.25 Carriage Bolt

8.6 Convey Hawk II – Lift Components

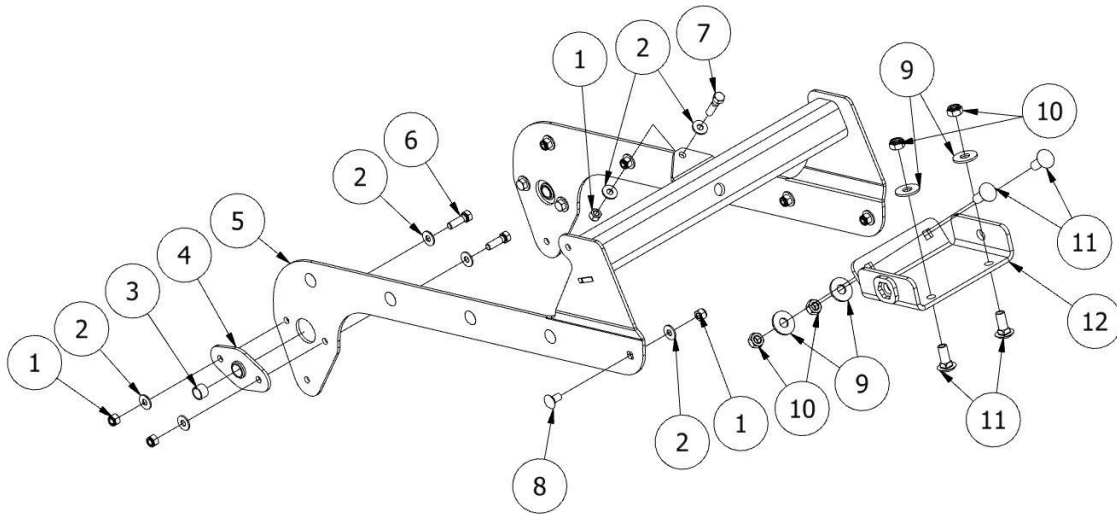

#	PART NUMBER	DESCRIPTION
1	0100-001102	3/8" Nylok Hex Nut
2	0101-001001	5/16" USS Flat Washer
3	0113-000077	Bushing 0.625ID x 0.75OD x 0.5long IGUS G300 GSI-1012-08
4	0013-001019	Idler Shaft Guide Assembly
5	0013-001034	Lift Panel Assembly
6	0105-000203	3/8" x 1-1/4" NC Hex Bolt
7	0105-000204	3/8" x 1-1/2" NC Hex Bolt
8	0105-009216	3/8" x 3/4" Carriage Bolt PLTD
9	0101-001004	1/2" USS Flat Washer
10	0100-001104	1/2 NC Nylok Hex Nut
11	0105-009417	1/2" x 1 1/4" Carriage Head GR5 Hex Cap Screw
12	0013-001027	Steel Hanger Bracket Assembly

8.7 0013-001303 Universal Spring Package

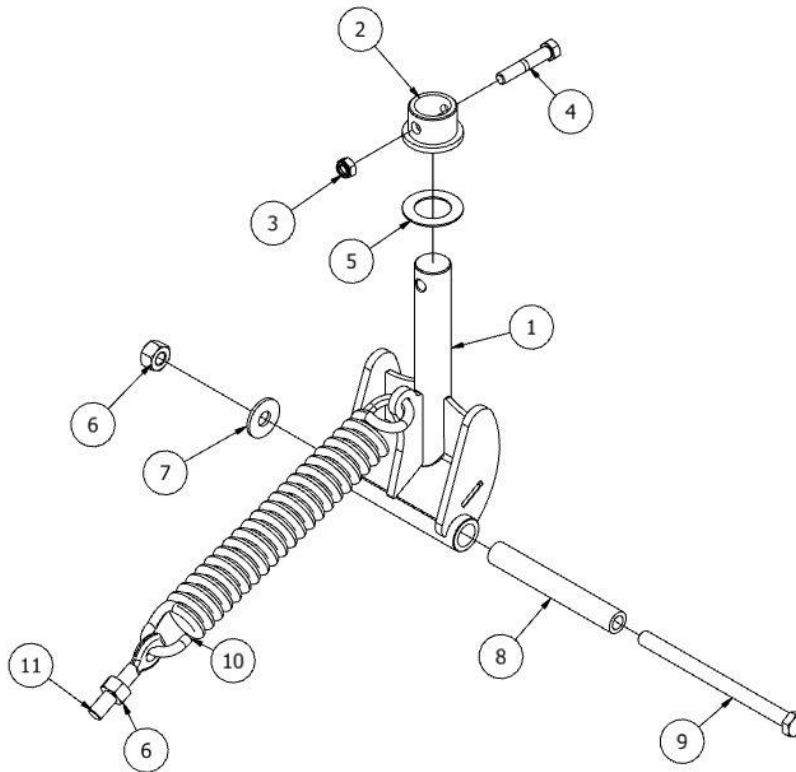

#	PART NUMBER	DESCRIPTION
1	0013-001303B	CH18 TC Universal Joint Single Spring
2	0013-000303C	CH18 TC Vert Pivot Cap
3	0100-001104	1/2 NC Nylok Hex Nut
4	0105-000409	1/2\"-13x2_3/4\"GR5 Hex Cap Screw
5	0101-001010	1-12 Flat Washer Hardened 1.531 ID x 0.075 Thick
6	0100-001105	5/8\" Nyloks Plated
7	0101-001005	5/8\" USS Flat Washer
8	0013-000303D	CH18 UB Nylatron Bushing
9	0105-000513	5/8\" x 8-1/2\" x 11Hex Cap Screw
10	0117-005000	Conveyor Spring
11	0105-000512	VC .625 x 5 Forged I-Bolt

8.8 0013-001307 Sub Frame Package

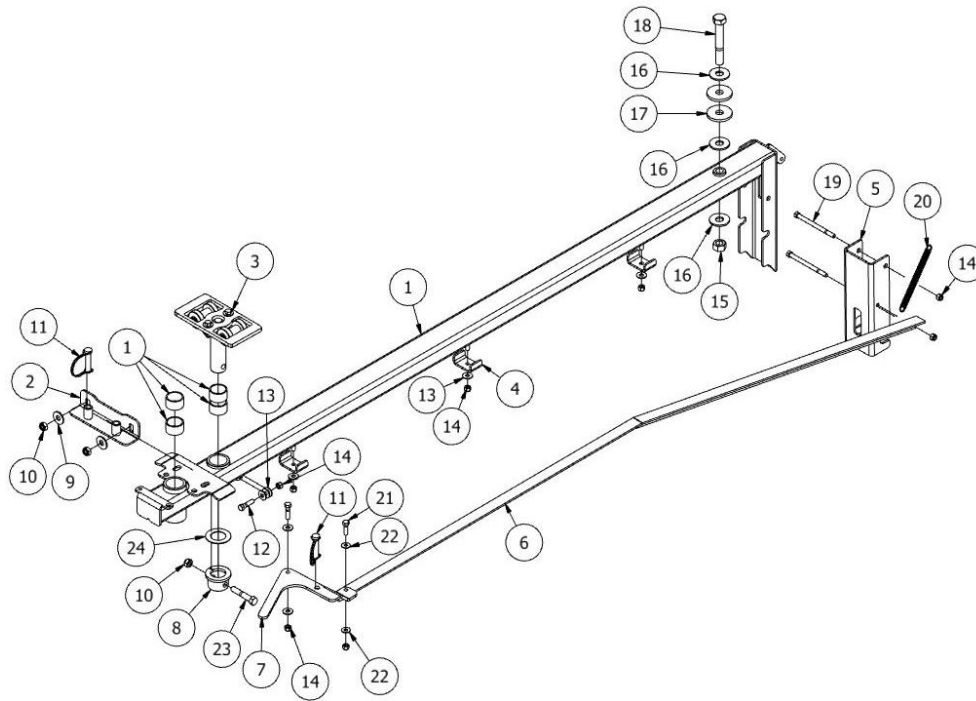

#	PART NUMBER	DESCRIPTION
1	0013-001307WF	CH18 Swinging Sub Frame
2	0013-000305	Ch18 SF Lock Plate Assembly
3	0013-000306	CH18 Swinging Trolley Assembly
4	0013-000301B	Ch18 Hose Clamp Half Inch (3/16" Steel)
5	0013-001307E	Pivot Lock Plate
6	0013-001307F	Lock Latch Puller Angle Iron
7	0013-001307D	Unlock Handle
8	0013-000303C	CH18 TC Vert Pivot Cap
9	0101-001004	1/2" USS Flat Washer
10	0100-001104	1/2 NC Nylok Hex Nut
11	0110-0000	1/2"x 2-1/2" Wire Lock Pin Snapper Round
12	0105-000204	3/8" x 1-1/2" NC Hex Bolt
13	0101-001002	3/8" USS Flat Washer
14	0100-001102	3/8" Nylok Hex Nut
15	0100-001106F	3/4 - 16 Hex Nuts (Inch Series) Hex Nut
16	0101-001006	3/4" USS Flat Washer
17	0013-000301A	CH18 Washer Pad 1/2" UHMW
18	0105-000615F	3/4"-16 x 5" GR5 Hex Cap Screw
19	0105-000218	Hex Bolt - UNC (Regular Thread - Inch)
20	0117-004000	Extension Spring
21	0105-000203	3/8" x 1-1/4" NC Hex Bolt
22	0101-001001	5/16" USS Flat Washer
23	0105-000409	1/2"-13x2_3/4"GR5 Hex Cap Screw
24	0101-001010	1-12 Flat Washer Hardened 1.531 ID x 0.075 Thick

8.9 0013-000306 Swinging Trolley Assembly Package

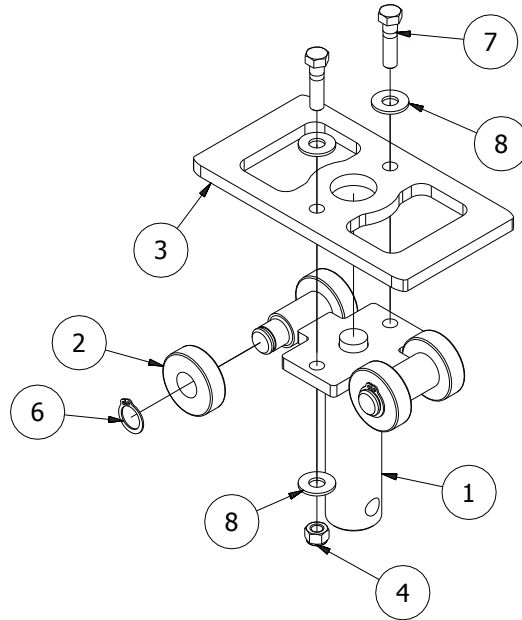

#	PART NUMBER	DESCRIPTION
1	0013-000306A	CH18 Swinging Trolley
2	0013-000306C	CH18 Bearing Nylatron NSM / GSM Bearing
3	0013-000306B	CH18 Alignment Pad
4	0100-001102	3/8" Nylok Hex Nut
6	0110-000101	Retaining Ring, External, 0.75 Shaft
7	0105-000204	3/8" x 1-1/2" NC Hex Bolt
8	0101-001002	3/8" USS Flat Washer

8.10 0013-000004 Standard Manual Hydraulic Flow Control

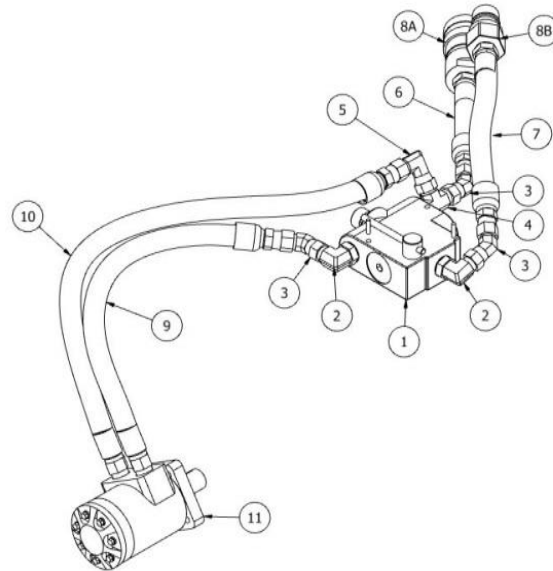

#	PART NUMBER	DESCRIPTION
1	0146-900003	Flow Control Valve c/w 10SAE Ports With Relief
2	0146-900008	#10 ORB Male x #8 JIC Male 90 Degree Elbow
3	0146-900016	8jic Female Swivel x 8jic male 45deg
4	0146-900007	#10 ORB Male x #8 JIC Male Tee
5	0146-900009	#8 JIC Female Swivel x #8 JIC Male 90 Degree Elbow
6	0146-900017	Hydraulic Hose Ass 1/2" Hose - #8 JIC Fem Swivel x 3/8" NPT Male- 9" long
7	0147-700018	Hydraulic Hose Ass 1/2" Hose - #8 JIC Fem Swivel x 3/8" NPT Male- 15" long
8	0146-300011	set of Quick Couplers Male & Female
8A	0146-300010	Quick Coupler Female - Pressure - Poppet Style
8B	0146-300012	Male Quick Coupler 1/2" - Poppet Style
9	0146-300004	Hydraulic Hose Ass 1/2" Hose - #8 JIC Fem Swivel x #10SAE ORB Male- 23" long
10	0146-300005	Hydraulic Hose Ass 1/2" Hose - #8 JIC Fem Swivel x #10SAE ORB Male- 30" long
11	0146-900002	Hyd Motor 101-1002-009

8.11 0013-000002 - 200 Series Wireless Hydraulic Components

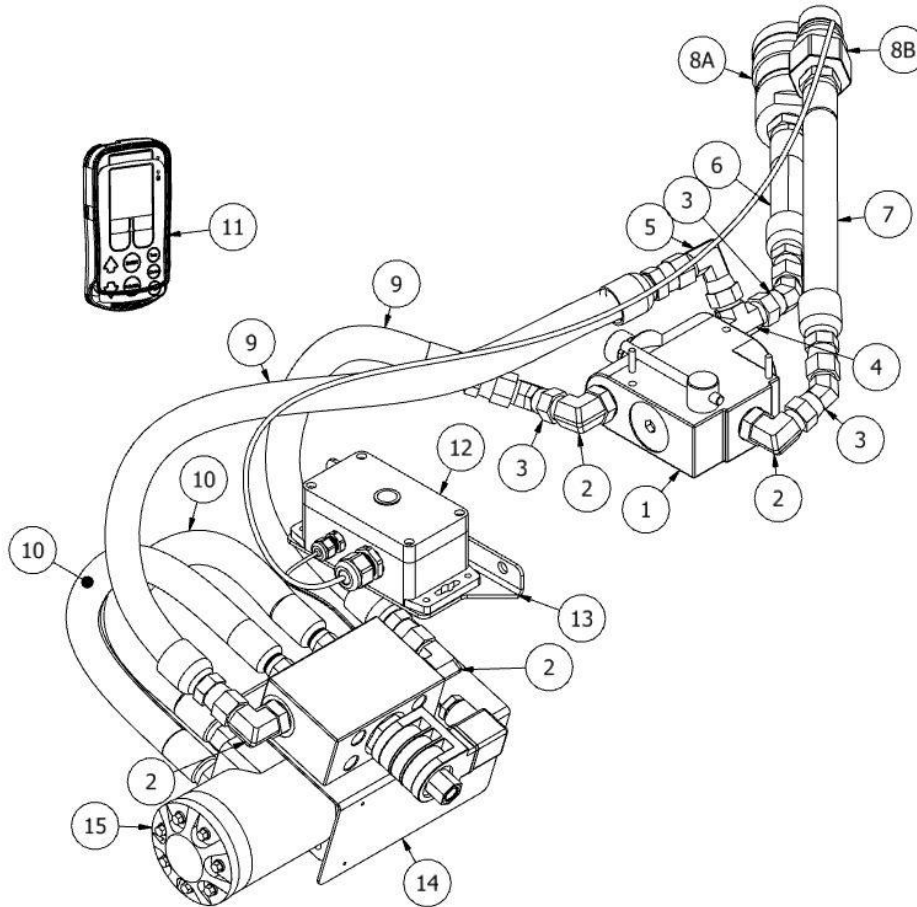

#	PART NUMBER	DESCRIPTION
1	0146-900003	Flow Control Valve c/w 10SAE Ports With Relief
2	0146-900008	#10 ORB Male x #8 JIC Male 90 Degree Elbow
3	0146-900016	8jic Female Swivel x 8jic male 45deg
4	0146-900007	#10 ORB Male x #8 JIC Male Tee
5	0146-900009	#8 JIC Female Swivel x #8 JIC Male 90 Degree Elbow
6	0146-900017	Hydraulic Hose Ass 1/2" Hose - #8 JIC Fem Swivel x 3/8" NPT Male- 9" long
7	0146-900018	Hydraulic Hose Ass 1/2" Hose - #8 JIC Fem Swivel x 3/8" NPT Male- 15" long
8	0146-300011	set of Quick Couplers Male & Female
8A	0146-300010	Quick Coupler Female - Pressure - Poppet Style
8B	0146-300012	Male Quick Coupler 1/2" - Poppet Style
9	0146-900020	Hydraulic Hose Ass 1/2" Hose - #8 JIC Fem Swivel Both Ends - 27" long
10	0146-900019	Hydraulic Hose Ass 1/2" Hose - #8 JIC Fem Swivel x #10SAE ORB Male- 21" long
11	0145-910060	R200 Remote - Used for All 200 Series Wireless Components
12	0013-000002B	Conveyor - Wireless add on with Chute Openers - conveyor
13	0013-000002C	Remote Button Bracket
14	0013-001012FW	Coupler Box Cover Wireless System
15	0146-900002	Hyd Motor 101-1002-009

8.12 0013-000332 Standard Fixed Frame Mounting Kit

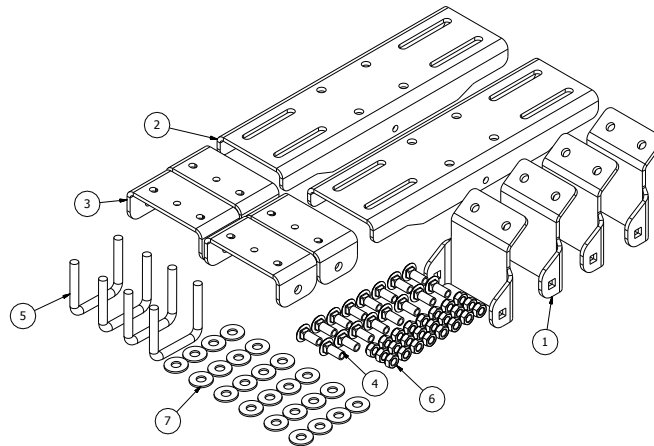

#	PART NUMBER	DESCRIPTION
1	0013-000315-6	CH18 SB Flex Upright MB
2	0013-000316-18	CH18 Channel Bracket Plate
3	0013-000314	Flex Bracket Base Plate (1/4" Steel)
4	0105-009417	1/2" x 1 1/4" Carriage Head GR5 Hex Cap Screw
5	0105-009418	1_2x3-1_16x3-1_4 Square bolt
6	0100-001104	1/2 NC Nylok Hex Nut
7	0101-001004	1/2" USS Flat Washer

8.13 0013-000330 Standard Swing Frame Mounting Kit

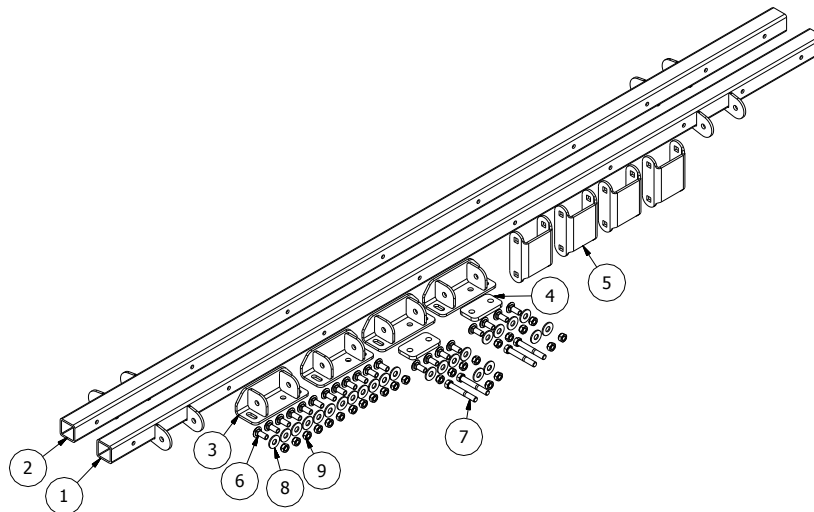

#	PART NUMBER	DESCRIPTION
1	0013-000310	CH18 Tube Style Mounting Frame
2	0013-000310MIR	CH18 Tube Style Mounting Frame MIR
3	0013-000311	CH18 Adjustable MB Conveyor
4	0013-000322	CH18 Flex Mount Back Plate
5	0013-000312-4	CH18 Flex Mount Center Plate
6	0105-009417	1/2" x 1 1/4" Carriage Head GR5 Hex Cap Screw
7	0105-000412	1/2"-13x3_1/2"GR5 Hex Cap Screw
8	0101-001004	1/2" USS Flat Washer
9	0100-001104	1/2 NC Nylok Hex Nut

8.14 0013-001200 Convey Hawk II Install/Storage Stand

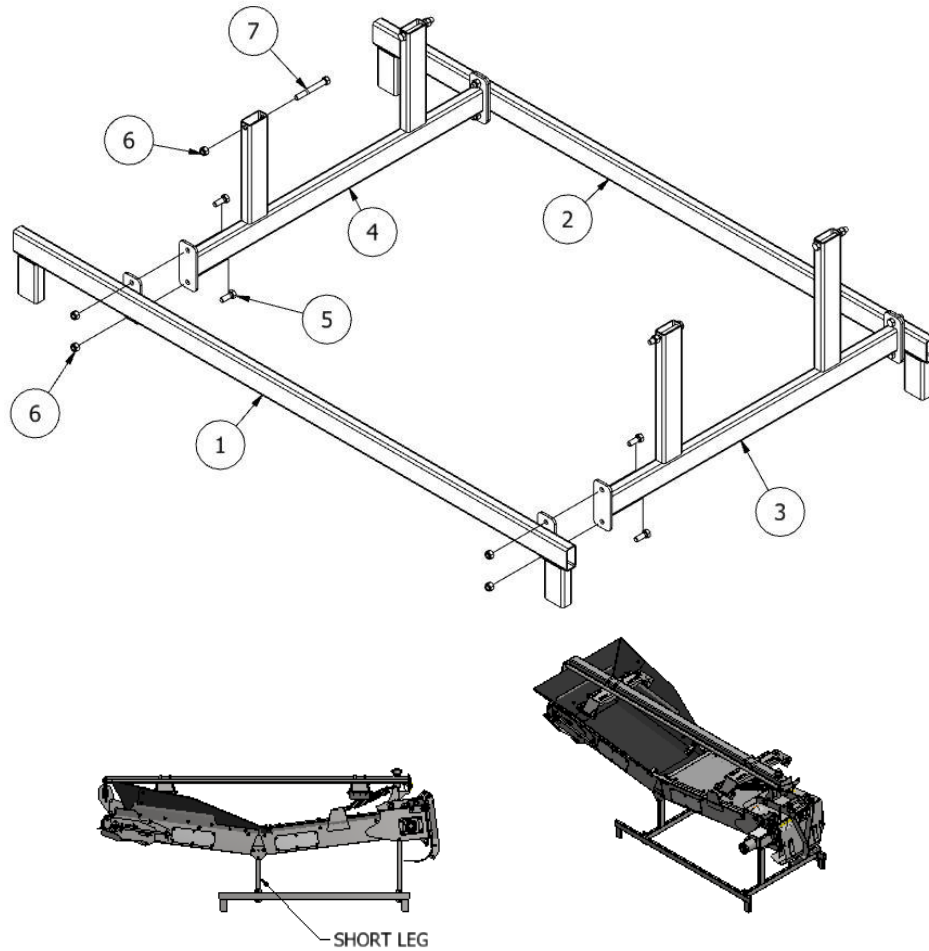

#	PART NUMBER	DESCRIPTION
1	0013-001200C	CH18 Conveyor Stand Left Side
2	0013-001200D	CH11 Conveyor Stand Right Side
3	0013-001200B	CH18 Conveyor Stand Tall End
4	0013-001200	CH11 Conveyor Stand Short End
5	0105-000202	3/8" x 1" NC Hex Bolt
6	0100-001102	3/8" Nylok Hex Nut
7	0105-000210	3/8" x 3" NC Hex Bolt

Note: The conveyor stand is for the installation, removal, and storage of the Convey Hawk II. It is designed to work with a standard pallet jack or forks on a front end loader. This stand makes it easier to attach and remove from the trailer.

8.15 0013-001400 - Convey Hawk II Portable Frame

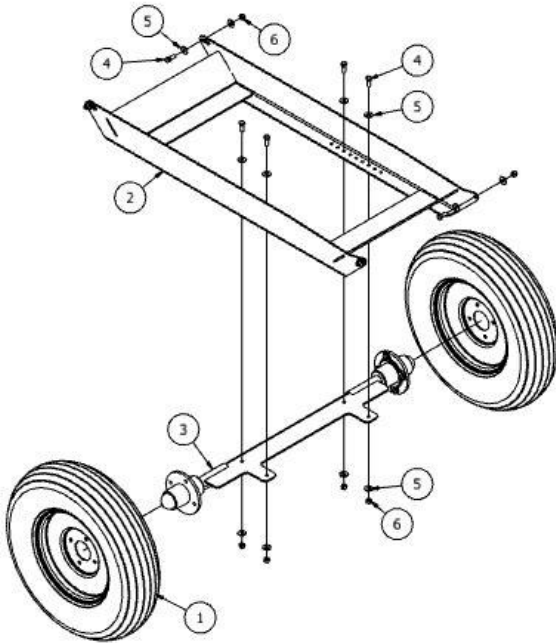

#	PART NUMBER	DESCRIPTION
1	0013-001100	5.30-12 Trailer Tire
2	0013-001401	Portable Aluminum Frame Assembly
3	0013-001402	Hub Axle Assembly
4	0105-000202	3/8" x 1" NC Hex Bolt
5	0101-001002	3/8" USS Flat Washer
6	0100-001102	3/8" Nylok Hex Nut

8.16 Convey Hawk Options

0013-000302-40 Fixed Sub Frame
Comes in different widths

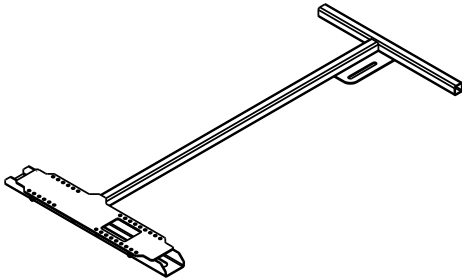

0013-000331 Standard
Chut Corner Deflector Kit

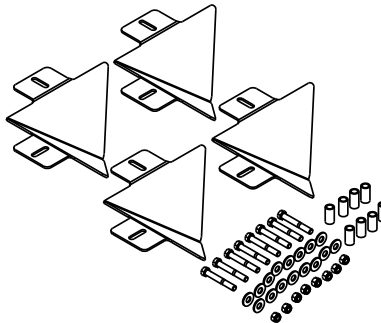

9.0 Contact Us

Michel's Industries, Ltd.

Box 119

St. Gregor, Saskatchewan,
Canada, S0K 3X0

Telephone: (306) 366-2184

Fax: (306) 366-2145

Email: sales@michels.ca

www.michels.ca