

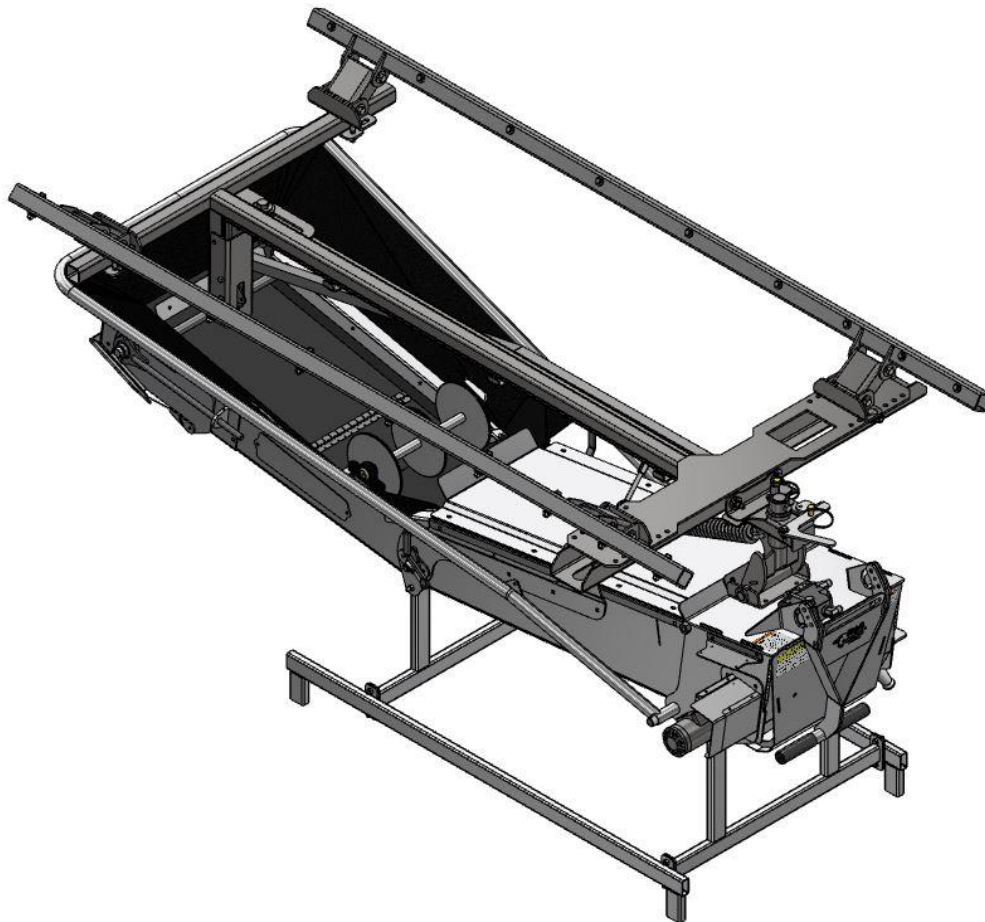

Swing Frame Installation Instructions



Michel's Industries, Ltd.
St. Gregor, SK., Canada S0K 3X0
PH: 306 366.2184 FX: 306 366.2145
EM:sales@michels.ca
www.michels.ca

Step 1

Remove the conveyor from the pallet and attach the installation/storage stand. Bolt the stand on using 3/8" x 1" bolts, 3/8" washers, and 3/8" Nylok Nuts. The short end of the stand will bolt to the middle of the conveyor.

The tall end gets bolted to the short side of the side rails and to the front of the conveyor.

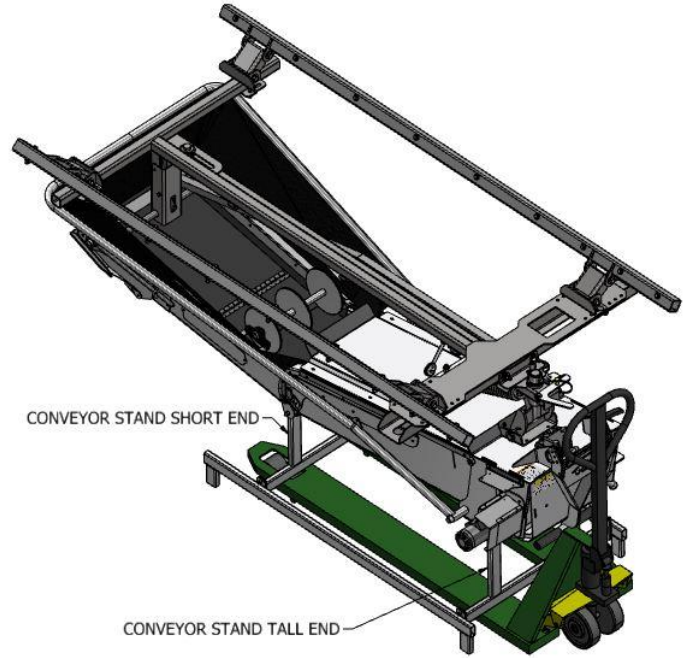

Step 2

Insert the Trolley assembly through the hole on the top of the swing frame. Next lay the swing frame on to the swinging sub frame. Aline the trolley so that it goes through the bushings in the swinging frame. Bolt the Pivot Cap onto the trolley. Grease both sides of the hardened steel washer with and both sides of the slide plate on the Main Swing Frame.

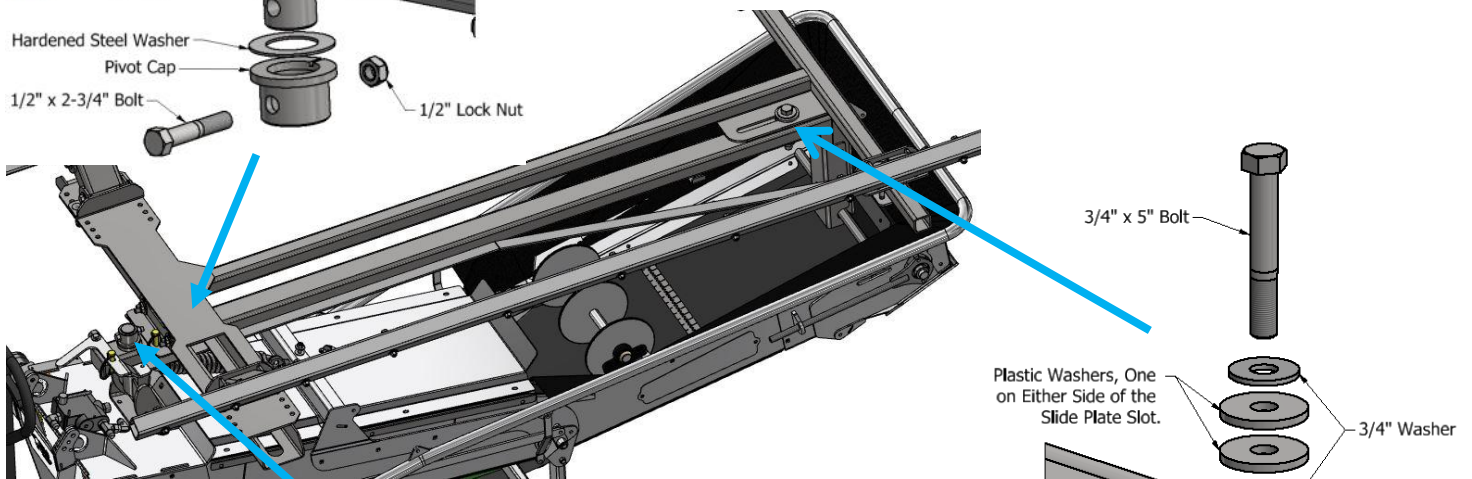
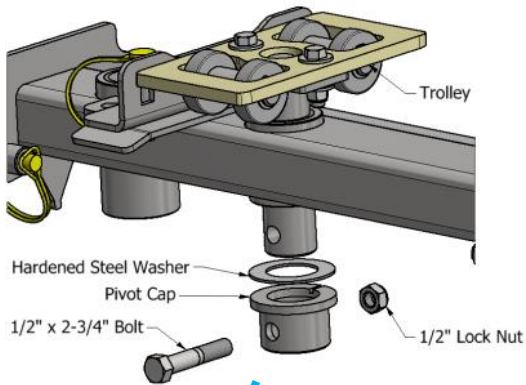

Step 3

Install the 1/2" x 1-1/4" Carriage Head Bolts into the swing Frame. Attach the Lock Plate Bracket with 1/2" Washers and 1/2" Lock Nuts. Leave a little bit loose until later.

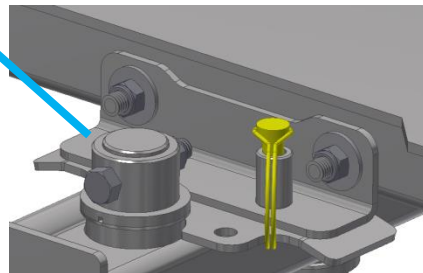

Step 4

You may need to move lights, air control box, or other things on the driver's side of the trailer to make clearance for the conveyor. The rear mud flaps located between the hoppers will have to be temporarily removed. They can be reinstalled at the end of seeding when the conveyor is removed from the trailer and put into storage.

Step 5

Loosely install all of the mounting hardware onto the conveyor. The long side on the mounting tubing will go to the front of the Conveyor/Driver's side of the trailer.

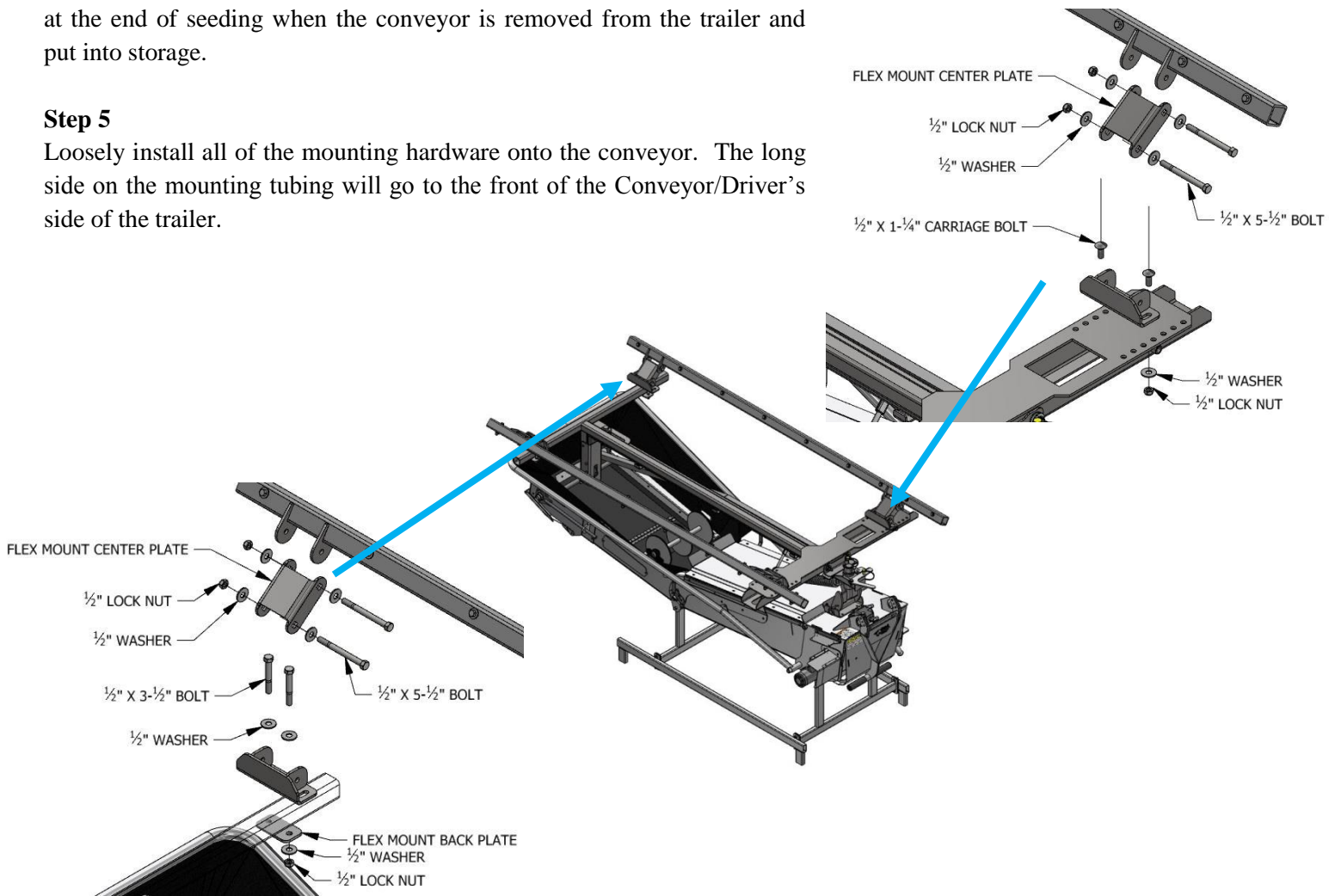

Step 6

Park the trailer on a flat and level area, preferably inside of a shop on a cement floor. The easiest way to move the conveyor around is to use a pallet jack. Center the pallet jack from side to side under the stand. If a pallet jack is not available, then it is possible to use forks on a front end loader or skid steer. Push the conveyor under the trailer so that it is close to being centered between the hoppers. Center the conveyor to the sides of the trailer. If mounting on a 8' trailer it is best to leave it hang out the passenger side. The mounting tubings are design to be bolted through the upper supporting brackets.

Step 7

Use a couple of 8' long 2x4's or some steel tubing to measure from the bottom of the trailer rail, to the bottom of the 2x4. The passenger side will be 1/4" longer in order to make the frame level to the trailer. A good starting measurement is approximately 1-1/2" to 2-1/2". The higher the frame it is mounted to the trailer the more ground clearance the conveyor will have. Center the conveyor from front to back between the hoppers. Measure both side to make sure that it is square to the trailer.

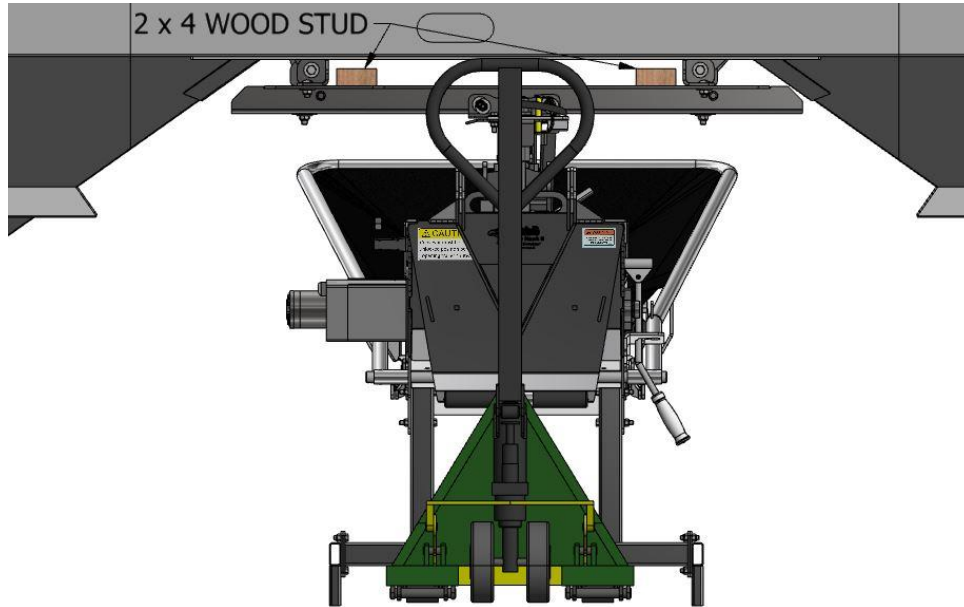

Step 8

Once the conveyor is positioned properly, drill 3/8" holes through the trailer cross support bracket. Some trailers need to have the tubing on the top of the support bracket while others will require it to be from the bottom up. It may be easier to clamp the tubing to the trailer and remove the rest of the conveyor for this process. For added safety and strength the mounting tubing can be welded to the trailer, as these do not have to be removed for storage.

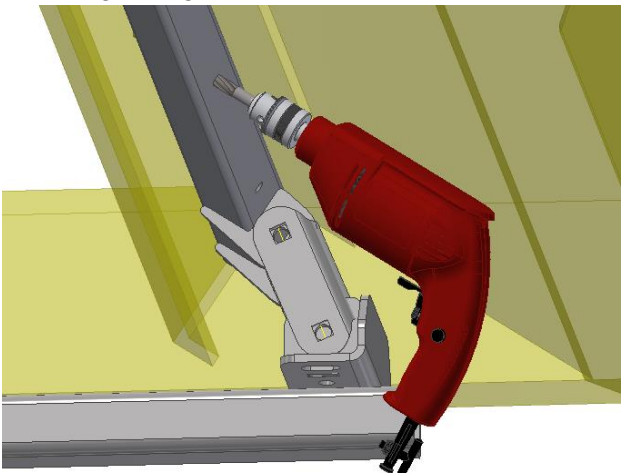

Picture showing drilling up through the support bracket.

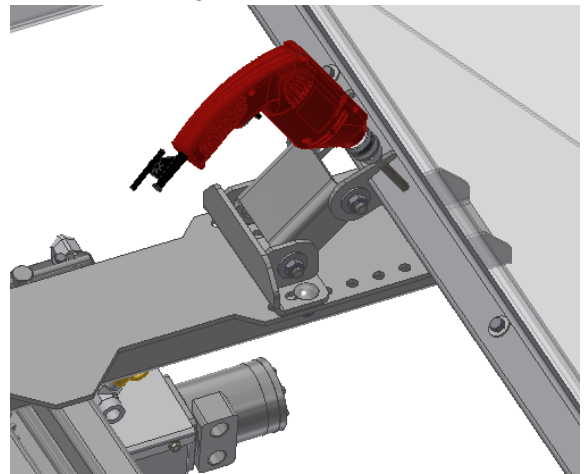

Picture showing drilling down through the support bracket.

Step 9

Once the tubing is secured to the trailer the conveyor mounting frame can be bolted up into position and the storage stand can be removed.

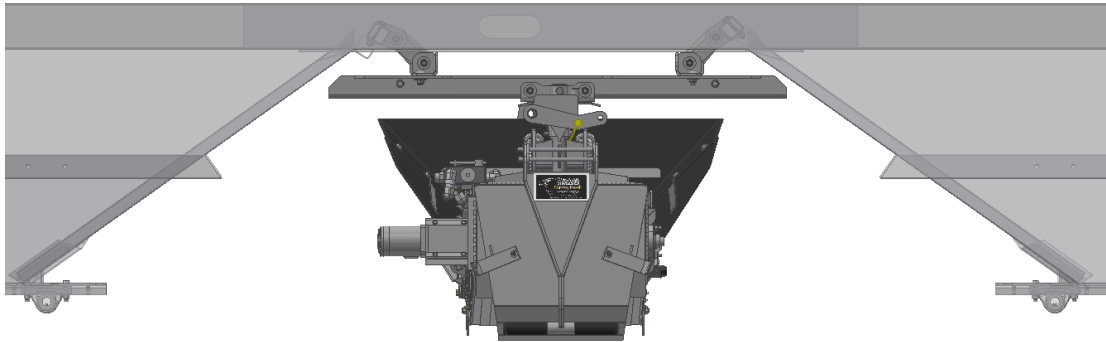

Step 10

With the conveyor centered, adjust the stabilizer plate to be down as far as possible. The stabilizer plate prevents the conveyor from rocking while the trailer is in transport.

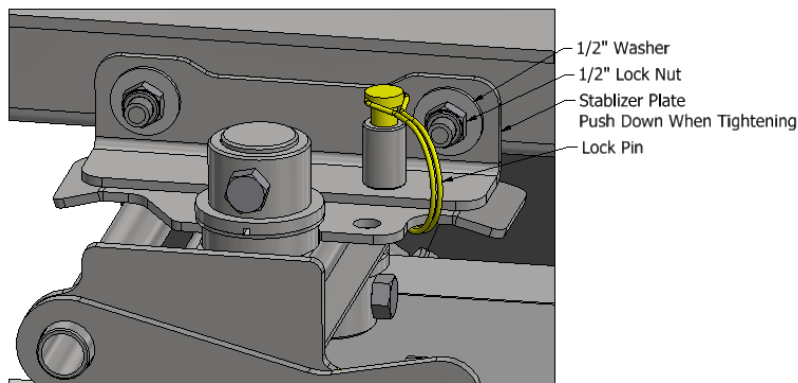

Step 11

Remove the Lock Pin and swing the conveyor all the way to the front. While putting downward pressure onto the handle of the conveyor pull on the release handle and lower the conveyor to the ground. Swing the conveyor to the front hopper. Position the Corner Extender Plate in the location that will direct the product into the hopper of the conveyor. Drill 3/8" holes through the flange of the chute. Install the Corner Extender Plate with 3/8" bolts, washers, and the supplied spacer tube. Repeat for the rear hopper. Note: Some trailers do not require the Corner Extender Plate. It is also possible that the Corner Extender Plates will be more complex.

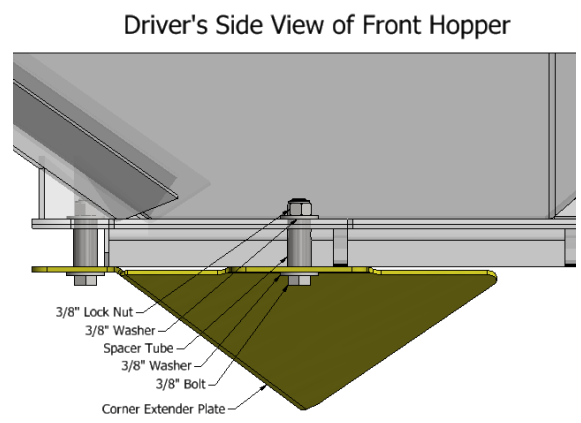
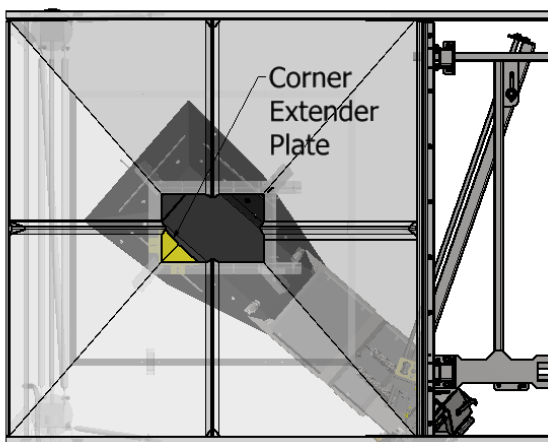

Step 12

While the conveyor is in this position, bolt the center chain to the Conveyor between the springs and onto the swinging sub frame. The chain is there to make it easier to position the conveyor in the correct location. Raise the conveyor and swing it to the rear of the trailer and make sure that the chain positions the conveyor in the correct place. Adjust chain if necessary.

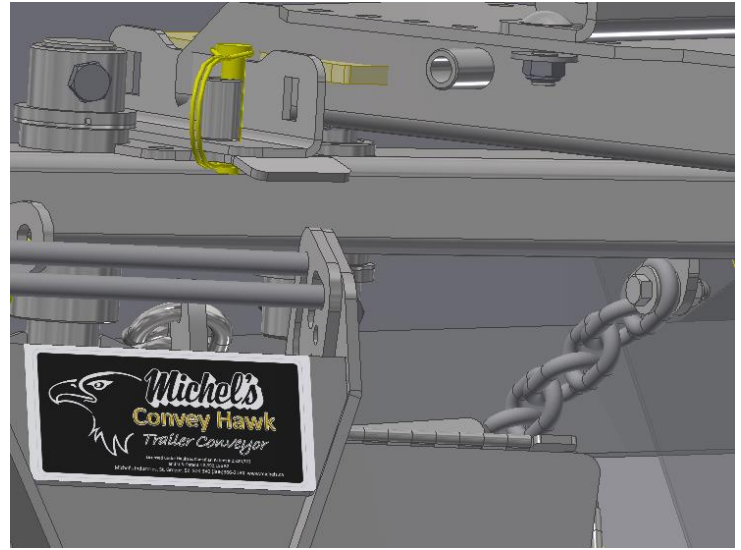
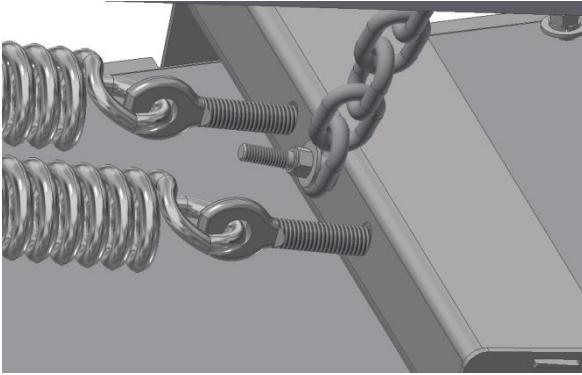

Step 13

Position the conveyor back under the front trailer hopper. Install the hoses onto the hydraulic control block first. There are short hoses already installed on the conveyor that include a set of Pioneer® quick couplers. Run the hoses along the bottom side of the swinging arm using the hose clamps and route to the front of the trailer or to the air seeder. Make sure that there is enough slack that the conveyor will swing both directions.

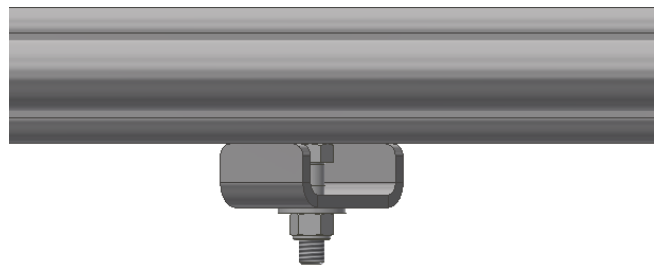
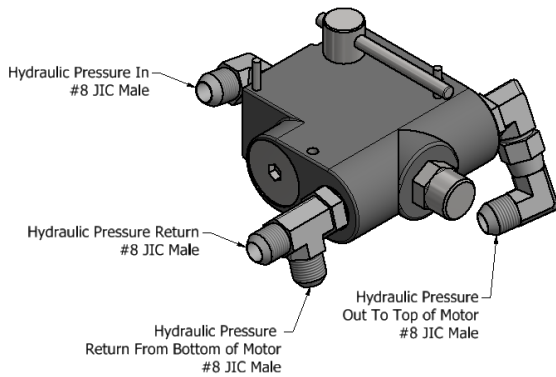

Note:

Refer to the Operator and Parts Manual for general operation of your new Michel's Convey Hawk. If your Convey Hawk is equipped with a wireless remote, refer to the Wireless Operation and Instruction Manual that came with the remote.