

NEW!



Aero Industries has designed a rolling tarp system that provides security and protection for loads best carried on a flatbed trailer. The Conestoga XP™ transforms a flatbed into a fully covered, weatherproof van in a matter of minutes. Instead of climbing over the trailer and tying down a tarp, the Conestoga XP allows drivers to cover and uncover cargo in minutes as they safely walk alongside the trailer.

Conestoga XP is the newest generation of rolling tarp systems from Aero Industries. Named after the covered wagon of early pioneers, Aero's® original Conestoga® featured an innovative rolling tarp that covered and uncovered a flatbed trailer in minutes. Now, Conestoga XP adds many new features to improve this unique system and offers additional options.

Attractive, durable and easy to use, the Conestoga XP features a front and rear locking mechanism which allows the system to be locked in seconds and ensures uniform tarp tension. It also features steel wheels on a stainless steel track. Conestoga XP is made to your specifications, ensuring a perfect fit for 96" or 102" flatbeds.

Call us today at 1-800-535-9545 to learn how the Conestoga XP can add speed, safety and productivity to your business.



For more than 60 years, Aero Industries, Inc. has been pioneering innovative accessories for the transportation industry. We've taken that expertise and designed a rolling tarp system that outperforms any other on the market today, with an attractive appearance and increased functionality, safety, convenience and durability.



Call Aero today at 1-800-535-9545 or visit us online at www.aeroindustries.com



New Special Features

- Front unlocks while the tarp is locked in the rear
- No special tool required to lock/unlock system
- 23" front and rear cars and 10" intermediate cars—less space when collapsed
- System collapses at any part of the trailer providing complete access to the load



Load & Go!

The Conestoga XP™ can transform your flatbed into a fully covered, weatherproof van in minutes. Aero's innovative rolling tarp system, the Conestoga XP, offers an attractive appearance, loads easily, covers quickly, offers full protection from the elements, increases safety and saves you time and money.

Aero Industries, Inc. has been the industry leader of cargo protection products for the transportation industry for more than 60 years. Call us today and let us show you how the Conestoga XP can save time and money—and say good-bye to blood, sweat and tarps!



Call 1-800-535-9545
www.aeroindustries.com

INDIANAPOLIS, IN
Indianapolis, IN 46241
800-535-9545
FAX: 317-244-1311

OMAHA, NE
Omaha, NE 68137
800-535-8552
FAX: 402-895-6129

STREETSBORO, OH
Streetsboro, OH 44241
888-237-2262
FAX: 330-626-3277



© 2012 Aero Industries, Inc. Aero®, Conestoga®, Conestoga 2® and Conestoga XP™ are trademarks of Aero Industries, Inc. Covered by one or more of the following patents in the U.S. 7494177, 7325855, 7249796, 7229120, 6793273, 6511117, 6419301, 5538313, 5080423, 5026109, 4902064, 4711484. -- in Canada 2625980, 2610565, 2471029, 2456448, 2159749, 1290786.



Tarp System Innovation
Since 1944



Rolling Tarp System



Protection of a Dry Van. Versatility of a Flatbed.

Attractive Appearance The panelized tarp gives an attractive, tight look, highlighted by the sleek front bulkhead.

Quick Operation The single motion over-center front and rear locks provide a fast solution to accessing the trailer.

Saves Time and Money A full load can be covered in seconds. That saves time, and time is money.

Loads Easily Tarp quickly slides into any position for easy loading and unloading.

Low Maintenance The Conestoga® XP™ is practically maintenance-free.

Better Protection The tarp is weatherproof and watertight, completely protecting valuable loads.

Increased Safety The entire system is operated from the ground.

Continuous Advertising Digital or custom painted graphics can be placed on the tarp, providing permanent advertising.

To see a video of the Conestoga® XP™ in action, visit www.aeroindustries.com



Front Speed Locks

- Operated from the ground for increased safety—no climbing on trailer
- Double toggle latch tightly secures the front bow to the bulkhead without cranking
- Fast, easy, secure
- Ensures positive locking and watertight seal
- Front unlocks while the tarp is locked in the rear



Wheel & Track System

- Steel wheels glide easily on a stainless steel track insert
- Steel-on-steel design facilitates smooth opening and closing
- Eliminates costly downtime and maintenance
- Sealed bearings require no maintenance
- Wheels covered by **Lifetime Warranty**
- Patented built-in bump rail protects track from forklifts and other loading hazards and automatically ensures a watertight seal for the tarp

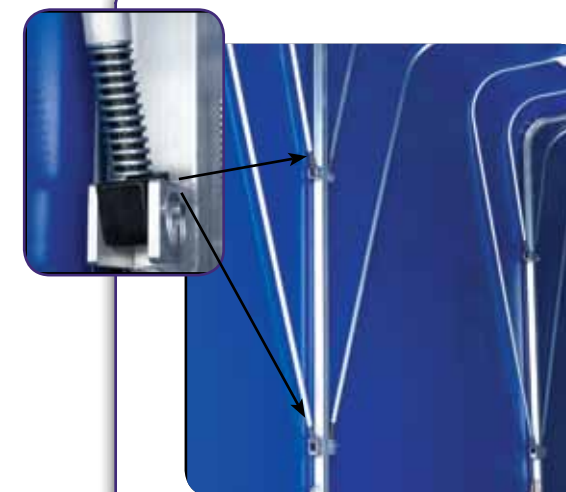
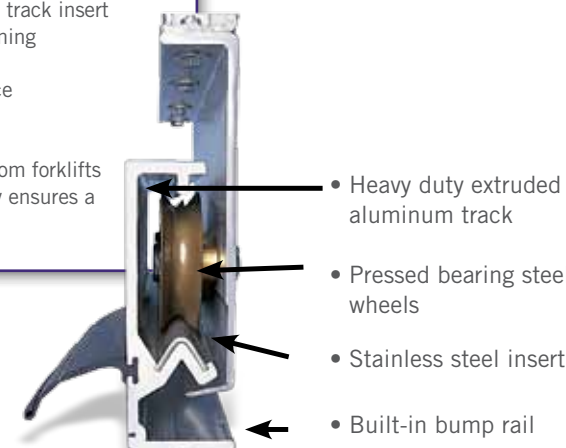

Uplift Bows

- Reduces tarp pleating to maximize inside loading clearance
- Choose from Quad, Double or Quint Uplift Bows
 - Quad Bows designed for tall loads; reduce tarp sag to 4-6"
 - Double Uplift Bows reduce tarp sag to 8-10"
 - Quint Bows reduce tarp sag to 2-3"
- Patented spring shocks on uplift bows reduce vibrations from road conditions and maximize tarp lift
- Less wear and tear on tarp
- Virtually maintenance-free—no fastener



Panelized Tarp

- Seamless, one-piece appearance
- Easy to remove sections
- Reduces tarp repairs and replacement costs
- Hides aluminum bows for continuous, one-piece look
- Automatically seals against track and bump rail for watertight fit
- Urethane topcoat available in a variety of colors
- Optional skylight available—every other panel
- Ideal for custom painted or digital graphics
- Patented feature



Custom digital or vinyl ink graphics available.

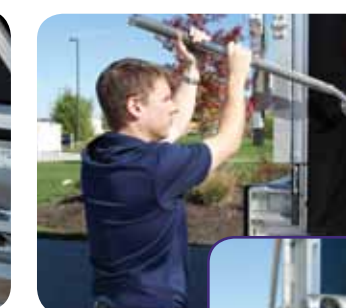
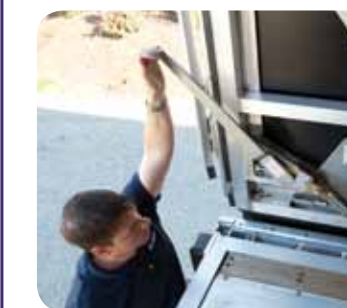

Rear Speed Locks

- Operated from the ground for increased safety—no climbing on trailer
- Single motion release provides fast operation
- No cumbersome straps to remove or store
- All lock components travel with rear bow assembly—no loading obstructions
- Lock allows for optimal tarp tension
- Operated from the inside and outside
- Winch bar adapter included—no special tool required