

## GENERIC Order Form

Customer Name: \_\_\_\_\_ Fax#: ( ) \_\_\_\_\_

Address: \_\_\_\_\_ Ph#: ( ) \_\_\_\_\_

Make of Trailer: \_\_\_\_\_ Year of Trailer: \_\_\_\_\_

Length of Trailer: \_\_\_\_\_ Steel or Aluminium: \_\_\_\_\_ Serial # \_\_\_\_\_

Width of Trailer: 8' or 8'6"

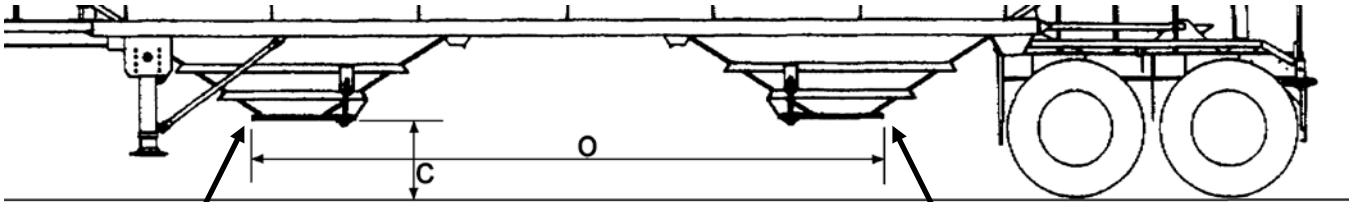

\*\*\*Hook Tape Measure on Angle Iron which hangs down\*\*\*

**Please give exact measurements to the nearest 1/16" of an inch**

1. Bottom of Hopper to the Ground (C): \_\_\_\_\_

2. Front of Front Hopper to Rear of Rear Hopper (O): \_\_\_\_\_

(Please Note: If Chutes both open to the outside you must measure in-between The pillow blocks of each hopper. If only one chute opens outward measure from The outside of the chute up to the start of that particular pillow block)

3. Outside Width of Chute (OW): \_\_\_\_\_

4. Front of Chute up to the start of the Pillow Block (OL): \_\_\_\_\_

5. Which way the Chutes Open:

Both to Middle    Both to Front of Trailer    Both to Outside    Both to Rear of Trailer

6. Number of Axles: \_\_\_\_\_

7. Number of Hoppers: \_\_\_\_\_

8. Number of Hoppers between Axles and Tractor Unit: \_\_\_\_\_

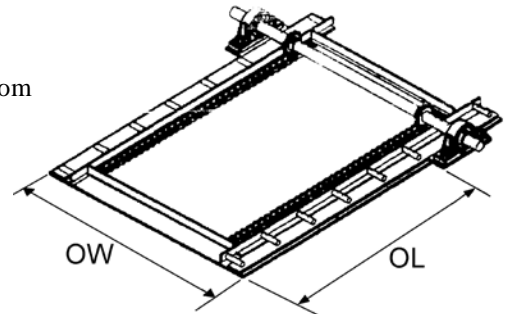

**Please Circle Options**

**Manual Flow Controls    or    3 Button Wireless Remote    or**  
**T200 Multi-Function Wireless Remote** (Can control future functions like Tarp, Chute Openers, lights or swing auger mover with same remote)

**8"    or    10"**

**Steel Shell    or    Aluminium Shell**

**Please give exact measurements to the nearest 1/16" of an inch**

For any questions on this order form please contact Michel's Industries.

NOTE: Michel's is not responsible for any incorrect measurements