

# Michel's

## **E<sub>Z</sub> OPENER** **210**

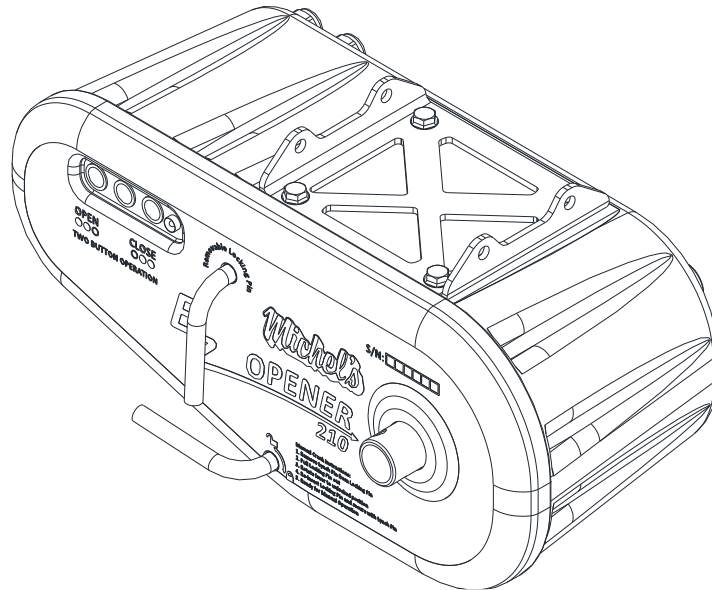

**Please Forward to End User**

**For user operation and setting limits refer to the R210 / R200 Remote Manual.**

*Scan for Installation Videos of the Remote Setup*



## Contents

1.0 Installing the Chute Opener .....	2
1.1 Manual Crank Option .....	4
2.0 Wiring the Chute Openers .....	5
2.1 Wiring of the trailer .....	6
2.2 Super B Wiring .....	7
2.3 Wiring of the Highway Tractor.....	7
3.0 Manual Operation.....	8
4.0 Chute Opener Lights .....	9
5.0 Chute Opener Operation .....	10
6.0 Warranty .....	11

Please read these instructions and the R200 Remote Instructions in their entirety before starting. **DO NOT disengage the motor OR run the motor until directed to do so.** Changing the position of the output shaft could cause damage to the chute opener and trailer or may prevent the chute from completely opening or closing.

## 1.0 Installing the Chute Opener

The chute openers can be installed in a variety of ways depending on the customer and the trailer. The chute openers can be mounted on either side of the trailer. If they are being installed on a 3 hopper trailer that will also have Michel's Hopper Augers, the opener will likely have to be mounted on the passenger side.

To install the chute openers, the top bearing and holders have to be removed to allow the chute opener to be mounted to the top support flange of the trailer.

There are two different ways of removing the bearings from the shaft and installing the openers. The first option will typically be used for aftermarket installations. Typically the shaft will be painted and or pitted from rocks which will make it difficult to remove the bearing. The crank shaft may also be seized in the u-joints.

### **Option 1 – Cutting the existing Crank Shaft.**

Cut the crank shaft 1" behind the bearing with a cut off wheel.

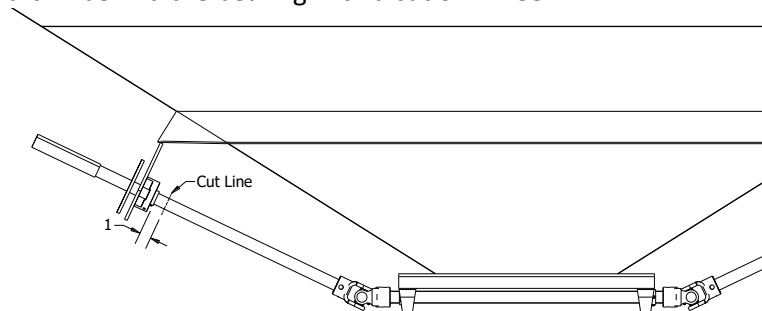

Remove the bearing from the shaft.

Remove the bracket that supports the crank/bearing by unbolting it, or by cutting the bracket off entirely.

Slide the chute opener onto the shaft that is attached to the U-joint with the front face of the opener facing away from the trailer.

### **Option 2 – Removing Existing Shaft from U-Joint**

Remove the shaft from the U-joint. It may be required to heat up the shaft and may require the use of an air hammer.

Slide the bearing off of the shaft.

Remove the bracket that supports the crank/bearing by unbolting it, or by cutting off the bracket. Slide the chute opener on the shaft with the front face of the opener facing away from the trailer when the crank shaft is reinstalled.

Secure the crank shaft back to the u-joint.

If you know where the center of the shaft of the chute is on the support flange then mark  $3\frac{3}{4}$ " to the left of center. This mark will now be the center of the trailer mounting bracket. The only way to know where center is from the bearing holder is if it was aligned with chute shaft. Lode King trailers are not aligned.

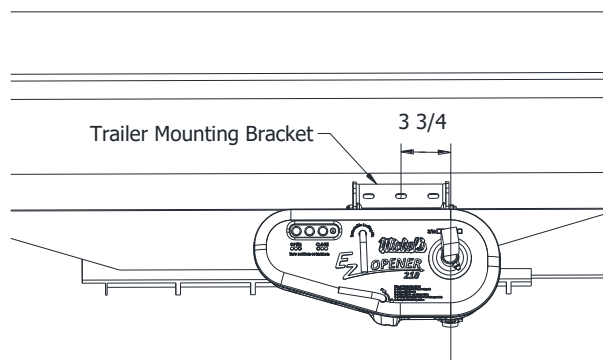

Raise the chute opener and position it so it is as high as possible with the trailer bracket mating on the flange on the hopper. The trailer bracket may have to be moved around on the opener to achieve the best position. On aluminum trailers, the mounting bracket will typically only be allowed to be mounted on one side of the support flange because one side is typically not flat.

Clamp the trailer bracket to the trailer so the center hole of the trailer bracket is in line with the mark  $3\text{-}3/4$ " off center or have the crank shaft parallel with the shaft under the chute so it is square to the chute. If the location of the trailer mounting bracket is known, it may be easier to remove the bracket from the assembly and mount it to the trailer first and then re-attach the assembly. The trailer bracket should be flush with the bottom of the flange. On some aluminum trailers (Wilson), we recommend having the trailer bracket  $1/8$ " up from the bottom; this will allow the bolts to go through the flat portion of the support flange on the trailer.

***Depending on which way the chute opener was mounted on the trailer, it may be a good idea to make sure the crank shaft sticks out of the chute opener end or else the manual crank option will not be available. See below about the manual crank option.***

Drill three  $3/8$ " holes through the existing holes in the trailer bracket through the hopper flange. Secure to the flange with three  $3/8$ " x 1" hex bolts and nylon lock nuts.

Tighten the two  $3/8$ " carriage head bolts which hold the trailer bracket to the chute opener bracket. Try to position the chute opener so the crank shaft and the output shaft of the chute opener are parallel with each other.

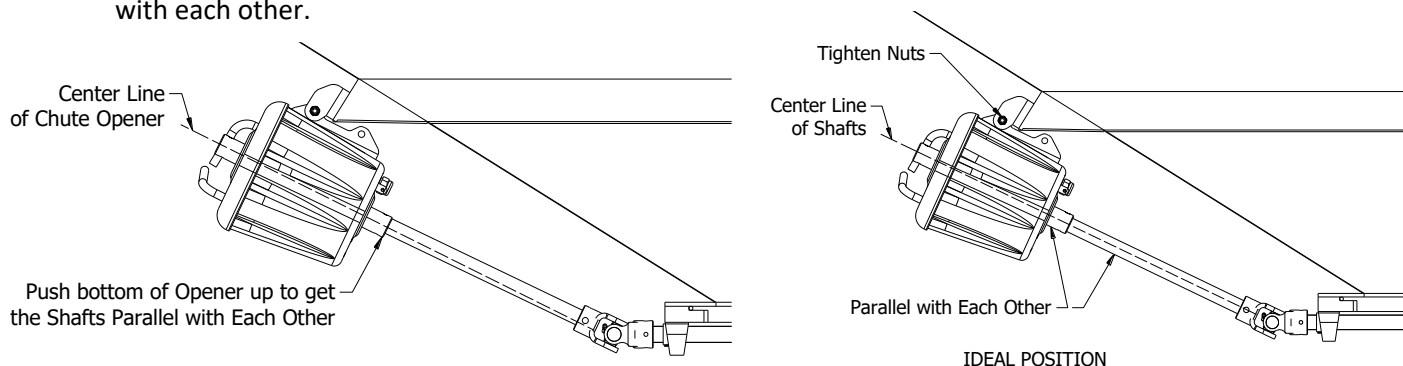

Have the chute open halfway so the positioning sensor inside can be set correctly.

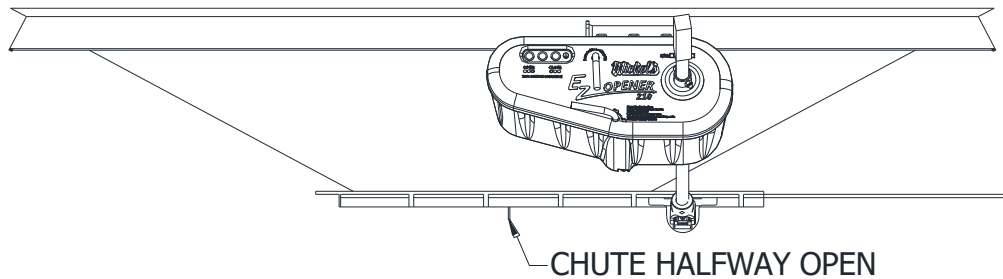

**Failure to do so could prevent you from fully opening or closing your chutes initially.**

With the crank shaft positioned correctly, drill through the back hole of the output shaft of the chute opener and crank shaft with a 13/32" drill bit. Secure the chute or the crank shaft to prevent it from turning when drilling.

Secure the two together with a 3/8" Shoulder Bolt x 1-1/2" long and 5/16" nylon lock nut. Ensure the bolt has a short enough thread to prevent squishing of the shaft when tightening.

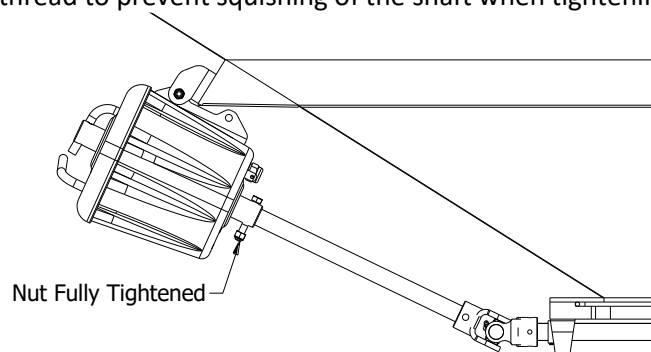

## 1.1 Manual Crank Option

Depending on the trailer it may be possible to secure the remaining crank shaft into the top of the output shaft of the chute opener to use for the manual crank if desired. On other trailers it may be required to modify the remaining shaft or make a smaller stub shaft to accommodate the manual crank or have the main crank shaft extend out the end of the chute opener to reattach the OEM crank end.

Drill through the front / top hole in the output shaft of the chute opener and the crank shaft with a 3/8" drill bit.

Secure the two together with a 3/8" Shoulder Bolt x 1-1/2" long and 5/16" nylon lock nut. Ensure the bolt has a short enough thread to prevent squishing of the shaft when tightening.

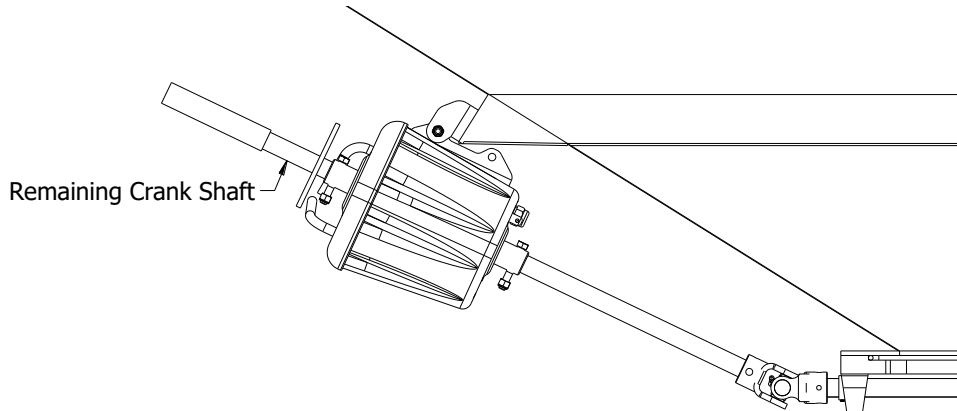

## 2.0 Wiring the Chute Openers

The chute openers will have one double strand 4 AWG power wire running from the battery to the junction box in the middle of the trailer.

If the chute openers are installed with a wireless tarp, the power will be split off the front trailer plug and the auger power will run off the junction box in the middle of the trailer instead of the clearance lights.

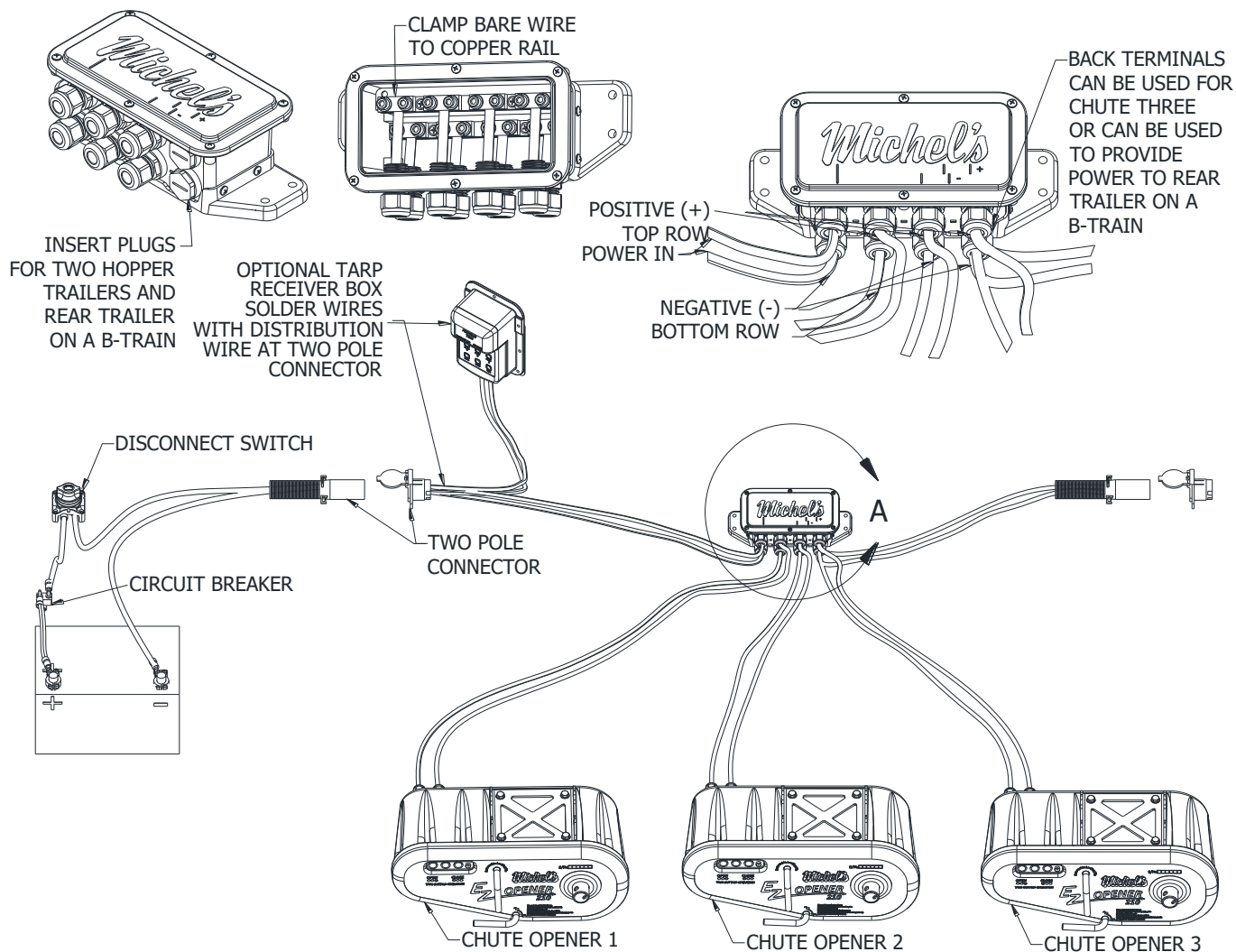

## 2.1 Wiring of the trailer

### **SOLID RED WIRE ON THE CHUTE OPENER IS POSITIVE (+)**

Drill a 2" hole at the front of the trailer for the 2 pole trailer socket. Depending on the trailer it will mount through the front wall by the other plugs or into the 5<sup>th</sup> wheel area. If you are drilling into the 5<sup>th</sup> wheel area, remove the top cover to ensure you are not drilling into any electrical or air lines.

Mount the electrical junction box in the middle of the trailer. The junction box will provide power to the chute openers mounted on the trailer. Mount the junction box on the same side of the chute openers and up in the slopes of the trailer as high as possible. Depending on the trailer you may need to mount it on the back of the support flange of the first hopper.

Secure the junction box with ¼" bolts to the middle of the hopper.

Run 4 AWG double strand wire from the 2" hole to the junction box. Run the wire so it is out the way of pinch points and road debris. If possible, run the wire in the side rail or along the existing electrical and air lines. Use the wire clips and plastic cable ties to secure the wire.

Use the markings on the cover of the junction box to strip the correct amount of insulation off of the power wire going into the junction box. Put the end of the positive wire on the line with the (+) and then strip the insulation off of the wire to the next line. Then use a knife to scrape off the ridge from that line to the far left line. This ridge would be what was left behind after the positive and negative wires were separated. **It is important to scrape off this ridge to ensure a proper seal with the strain relief connector.** Repeat this procedure for the negative wire using the line with the (-) to start with.

Insert the negative wire into the bottom left strain relief connector. Loosen the screws that hold the wire clamp in place on the copper rail. Insert the wire into the groove and tighten the screws to clamp the wire down. Tighten the strain relief until it is snug against the wire. Do not overtighten the strain relief or damage to the wire may occur. Repeat this step for the positive wire.

At the front of the trailer, solder two 4 AWG 1/4" solder lugs on the ends to secure to the trailer socket. Use the supplied heat shrink to seal the solder connection.

Before securing the soldered wire ends to the trailer socket, slide the rubber boot over the wire. Secure the positive wire to the terminal marked 'POS' on the trailer socket and negative wire to the terminal marked 'NEG'.

*Note: If a wireless tarp is also being installed you will also have a 6 AWG wire running to the wireless tarp box on the front of the trailer. Both wires will go through the rubber boot and connect to the trailer socket.*

Secure the 2 pole trailer socket to the trailer with two 3/8"x 1-1/4" self-threading bolts. Depending on the trailer you may want to put a backing plate behind it if the front wall is thin.

For each chute opener run the 6 AWG wire to the junction box. Follow existing electrical and air lines on the trailer to help make the installation as neat as possible. There are rubber grommets supplied to help protect the wires from the sharp edges of the holes. A 1-1/16" hole is required for the rubber grommets to fit properly.

Cut off any excess wire from the chute opener, after the wire from the chute opener has been run to the junction box. Strip the chute opener wires and connect the chute opener wires to the junction box the same way as the "power in" wire.

If the trailer is a two hopper trailer and if it is not the lead trailer on a B-train, insert the plugs into the remaining holes of the junction box if they are not already there.

Once all the wires are connected to the junction box, install the cover on the junction box.

## **2.2 Super B Wiring**

### **SOLID RED WIRE ON THE CHUTE OPENER IS POSITIVE (+)**

If you are installing the chute openers on a B-train, run a 4 AWG wire from the junction box of the front trailer to the front of the rear trailer. Follow the existing electrical and air lines to achieve a neat installation. Depending on the trailer it may be possible to run the wire in the side rail.

Secure the wire in place with wire clips and cable ties.

Connect these “power in” wires and the chute opener wires to the rear trailer junction box the same way as in Section 2.1.

Ensure that the plugs are installed in the last two ports of the junction box on the rear trailer.

At the back of the trailer leave enough slack in the wire to allow the trailer to turn and pivot.

Solder the 2 pole truck plug terminals to the 4 AWG wire. Ensure you place the positive wire (yellow or red) in the hole marked ‘POS’ and the negative wire in the hole marked ‘NEG’.

Repeat the above steps to wire the rear trailer.

## **2.3 Wiring of the Highway Tractor**

The highway tractor will require a power wire going from the battery to the front of the trailer. An auto reset breaker and power disconnect will be spliced into the positive wire.

Using ¼” x 1” lag screws mount the auto reset breaker in the battery box where it would be accessible for connecting wires.

Locate a good spot to mount the power disconnect switch either in the bunk storage compartment or in the cab of the truck where it is easily accessible and will be in a locked area to prevent tampering. Do not secure the disconnect switch to the truck yet.

Run 4 AWG double strand wire from the front of the trailer to the battery. Ensure there is enough slack in the wire to allow for turning.

Solder on the 2 pole truck plug terminals to the 4 AWG wire. Ensure you place the positive wire in the hole marked ‘POS’ and the negative wire in the hole marked ‘NEG’.

Split the 2 strand wire and loop the positive wire up to the switch before splicing the circuit breaker in. There are two smaller grommets which can be used to seal the wire when the switch is installed inside of the cab. It will be necessary to split the double strand wire to fit through the grommet. The grommets will require an 11/16” hole to be drilled.

At the switch solder two 3/8” solder lugs to the wire and apply the supplied heat shrink over the soldered connections.

Secure the wires to the switch and secure the switch to the truck using the four #8 x 2" sheet metal screws supplied. Ensure you are not drilling into any electrical components or to an outside wall because the screws will stick through.

Cut the positive wire to splice the circuit breaker inline and solder a ¼" solder lugs to the positive wire (yellow or red) and apply the supplied heat shrink over the soldered connection. Connect to the wire to the breaker with the side marked 'AUX' connected to the 2 pole plug.

Solder a 3/8" solder lug to the negative and positive wire and apply the supplied heat shrink over the soldered connection at the battery.

Secure the negative wire to the negative post of the battery.

Secure the positive wire to the positive post of the battery.

Insert the 2 pole plug into the trailer socket to power up the chute openers.

**ALWAYS disconnect the power when not in use or while travelling to prevent the chute openers from accidentally opening.**

**When washing the chute opener with a pressure washer hold the nozzle of the pressure washer at least 18 inches away. Failure to do so could cause water to get inside the chute opener under the seals and will void the warranty.**

***Once the chute openers are installed and wired, refer to the remote manual for operating instructions. The chute openers will need to be paired to the remote first, see section 4.1. of the R200 remote manual. We STRONGLY recommend reading sections 1, 2, 3 and the sections of the products you have before operating.***

**Do not use the chute openers until the limits are properly set otherwise damage to the trailer or chute opener could occur. See Section 7.2.1 of the R200 remote manual.**

### **3.0 Manual Operation**

If you lose power or experience motor failure you can disengage the motor and use the manual crank to operate the chutes.

Remove the lynch pin from the backside of the locking pin.

Pull the locking pin out of the opener. You may need to apply pressure to crank shaft to relieve the pressure from the gears inside to allow it to disengage.

Rotate the motor handle counter clockwise to disengage the motor.

You should now be able to turn the crank shaft manually.

Re-insert the locking pin to keep the motor disengaged and secure with the lynch pin.

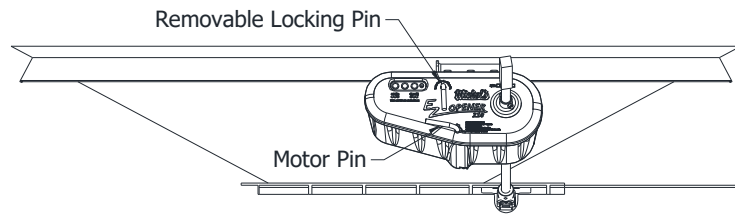

***Do not remove the 3/8" shoulder bolt that secures the crank shaft to the chute opener. If the crank shaft rotates while not secured to the chute opener output shaft, the limits will not be correct. With incorrect limits you could damage the trailer or chute opener.***

#### 4.0 Chute Opener Lights

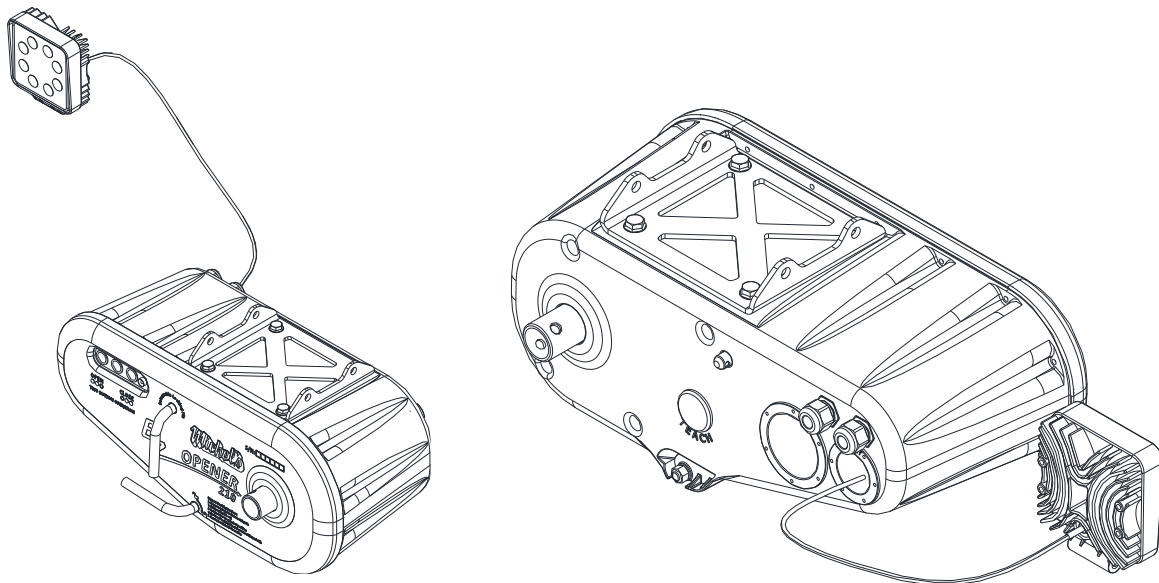

The Chute Opener Lights are an available, easy installation option for the EZ Opener 200. Most of the older chute openers are also upgradable to accommodate the light option, talk to your Michel's Industries sales rep for further details. The chute light is installed on the angle iron support of the chute and pointed toward the work area to assist in illuminating the chute gate opening for unloading at night. Mounting hardware is included with the light. Drill a 3/8" hole in the desired mounting location on the chute angle iron. Secure the light bracket to the chute. Insert the long bolt through the light and the light bracket. Pivot the light as required and tighten the long bolt. Plug the light into the chute opener. Use wire clips to tuck the wire away. See the R200 Remote Manual Section 7.2.0 for instruction on operating the light.

## 5.0 Chute Opener Operation

The EZ Opener 210 has three buttons on it which are used to control the direction of the chute gate. The center button must be pushed in conjunction with either the open or the close button to operate the chute. The center button acts as an additional safety feature to prevent accidental, undesired operation of the chute opener in the event a button should fail. At initial use, you have to tap them together for about second to activate the buttons since they will be in a sleep mode state.

**Note: ALWAYS disconnect the power when not in use or while travelling to prevent the chute openers from accidentally opening.**

**Note: Ensure there is gate lock on the trailer preventing the chute from operating before use.**

The EZ Opener 210 also comes with an indicator light which can be used to indicate whether the chute is open or closed. Please refer to the R200 / R210 Remote Manual Section 5.2.4 for further details on the set up the indicator light. The default setting for the indicator light is to flash if the chute is opened at all.

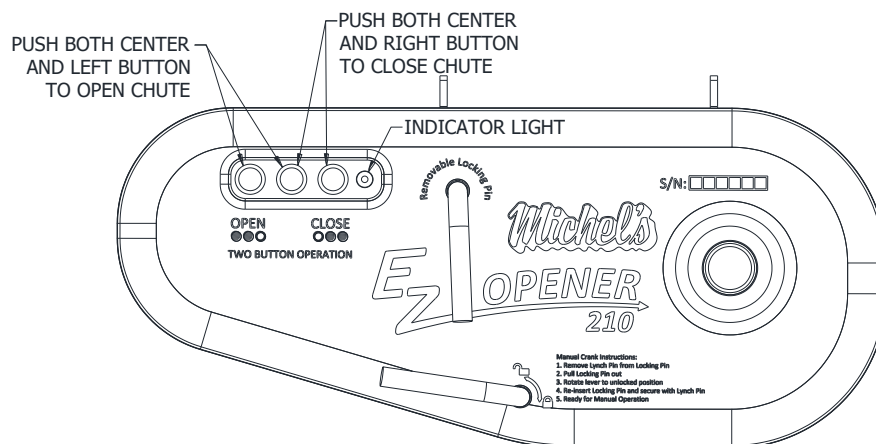

The EZ Opener 210 can have an additional auxiliary switch box connected to it to allow the operator to control the chute opener while standing on the opposite side of the trailer from the chute opener, if the R200 / R210 Remote Control is unavailable to the operator. Remove the larger size plug nearest to the power supply wires on the chute opener. Plug the auxiliary switch box into this socket. Run the cord across the trailer to the other side using the supplied wire clips to secure the cord to the trailer. Mount the auxiliary switch box in a convenient spot on the opposite side of the trailer. It works identically to the buttons on the chute opener and also comes with an indicator light. All EZ Opener 210 chute openers are manufactured ready to accept the auxiliary switch box with a socket to plug into on the chute opener. This switch box is sold as an option and can be purchased separate from or together with the chute opener. Contact a Michel's Industries Ltd. sales representative for further details.

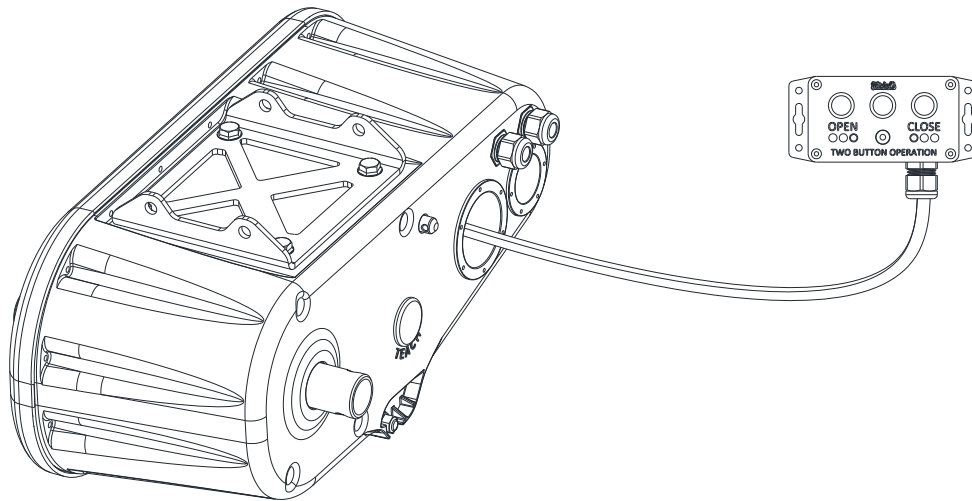

## 6.0 Warranty

Michel's Industries Ltd. provides a warranty on their products for a period of one year from date of purchase. Any parts returned to Michel's Industries Ltd. will be shipped prepaid by the customer and will be returned F.O.B. St. Gregor, Sk. Canada. We will not assume responsibility for shipping, labor or travel expenses. Please Note: We reserve the right to make improvements; therefore specifications are subject to change without notice.

***FOR ASSISTANCE PLEASE CALL (306) 366-2184***

Michel's Industries Ltd.  
P.O. Box 119  
St. Gregor, SK S0K 3X0  
CANADA

TEL: (306) 366-2184      FAX: (306) 366-2145

[www.michels.ca](http://www.michels.ca)