

Michel's

ECONO-FLIP

INSTALLATION INSTRUCTIONS

MICHEL'S INDUSTRIES, LTD.
P.O. BOX 119
ST. GREGOR, AK. S0K 3X0
PH: 306.366.2184 FX: 306.366.2145
EM: sales@michels.ca WWW.michels.ca

This page intentionally left blank

PLEASE READ ENTIRE INSTRUCTIONS BEFORE BEGINNING

Step 1: Roll-tube Bracket Installation
 (See Figure 1-2)

Procedure: Position the driver and passenger roll-tube brackets (A) along the front sides of the gravel box. The brackets should be mounted at a distance of 7" higher than the top of the box (see Figure 2). Using a 11/32" drill bit, drill 3 holes through the predrilled holes in the brackets and through the box. Fasten the driver and passenger roll-tube brackets to the box with the 3/8"x1-1/4" self-threading bolts (B) provided.

Note: If the brackets are to be mounted to the wood side-boards then drill 5 holes through the predrilled holes in the bracket and through the wood side boards. Fasten the brackets to the wood side boards with the 5/16"x2-1/2" hex bolts, 3/8" flat washers, and 5/16" nylon lock nuts provided.

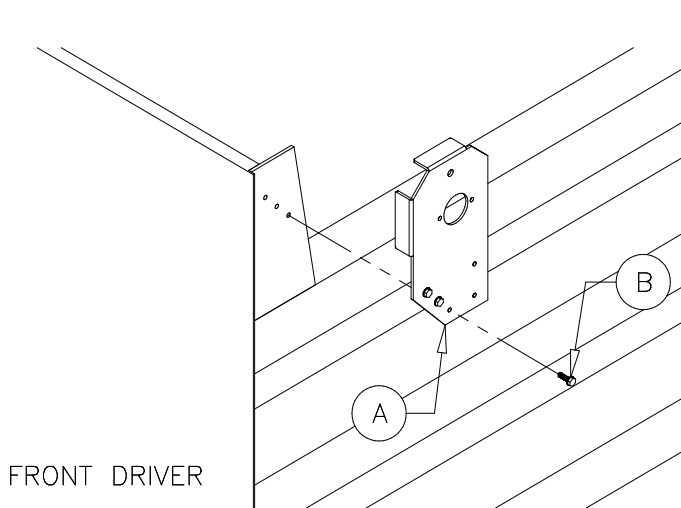

Figure 1

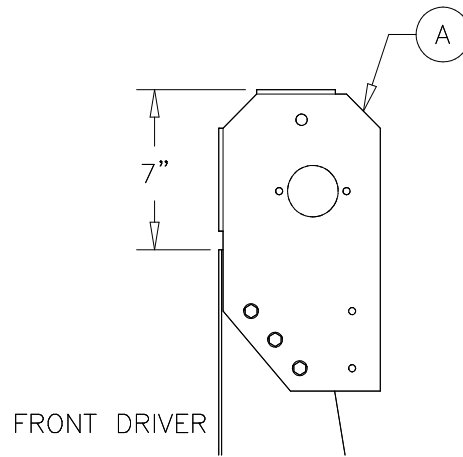

Figure 2

Step 2: Tarp Installation
 (See Figure 3)

Procedure: Slide the roll-tube (C) through the large pocket at the front of the tarp. Center the tarp material on the roll-tube. Remove any creases in the tarp along the roll-tube. Position a PVC front tarp clamp (D) on both edges of the tarp material. Fasten both tarp clamps to the tarp and roll-tube with the #10-24x3/4" wafer head screws (E) provided. Center and fasten the remaining two PVC front tarp clamps to the tarp material and roll-tube.

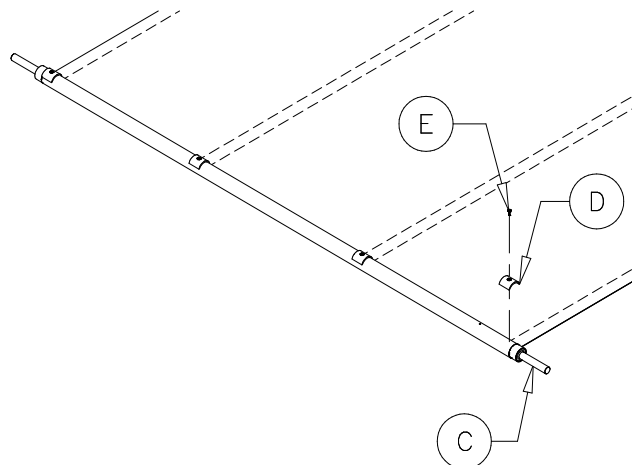

Figure 3

Step 3: Roll-tube Installation

(See Figure 4)

Procedure: Insert the roll-tube ends (C) through the large hole in the driver and passenger side roll-tube brackets. Slide the round flanges (F) and the UC205-16 self aligning bearing (G) on the roll-tube end (C). Fasten the flanges to the roll-tube brackets with the 5/16"x1" hex bolts (J), 5/16" flat washers and 5/16" nylon lock nuts provided. Center the roll-tube on the driver and passenger bracket. Tighten the grub screws in the UC205-16 bearings (G).

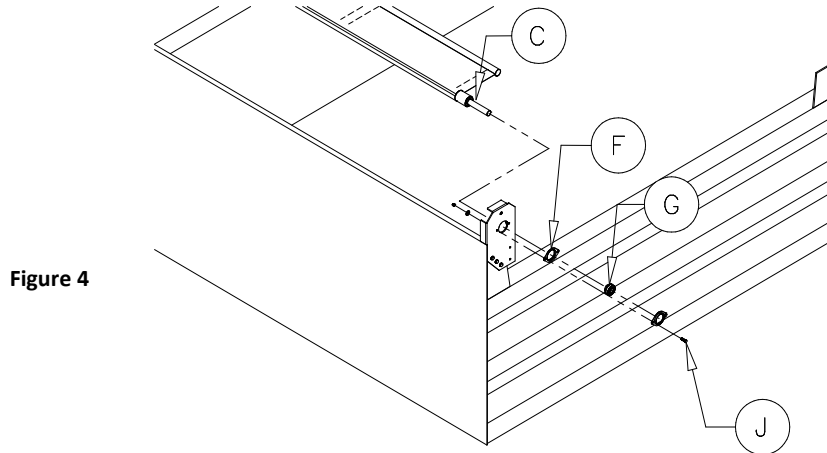

Figure 4

Step 4: Top Crank Installation (OPTIONAL)

(See Figure 5-7)

Note: See Step 5 for Bottom Crank Installation.
See Step 11 for Electric Motor Installation

Procedure: Attach the extension spring (K) to one of the 1/8"x3/4" cotter pins (L) provided. Insert the cotter pin into the predrilled hole in the top ratchet handle (M). Secure the cotter pin to the top ratchet handle. Slide the top crank handle (N) on the roll-tube end. Fasten the top ratchet handle (M) to the driver side roll-tube bracket with the 1/2"x2-1/2" hex bolt (O), 1/2" flat washers and 1/2" nylon lock nut.

Note: The top ratchet handle (M) must rotate freely on the 1/2"x2-1/2" hex bolt (O).

Insert the opposite end of extension spring (K) into the other cotter pin (L) provided. Insert the cotter pin into the predrilled hole in the roll-tube bracket (A). Secure the cotter pin to the roll-tube bracket. Adjust the top crank so the sprocket teeth make contact with the top ratchet handle (M). Remove the 5/16"x3/4" set screws from the 1X hub. Mark the location of the two 5/16" threaded holes in the 1X hub. Using a 5/16" drill bit, drill two holes in the roll-tube end approximately 1/4" deep. Secure the top crank to the roll-tube end with the 5/16"x3/4" set screws.

Note: The roll-tube end may have to be cut to a shorter length before the top crank can be properly installed.

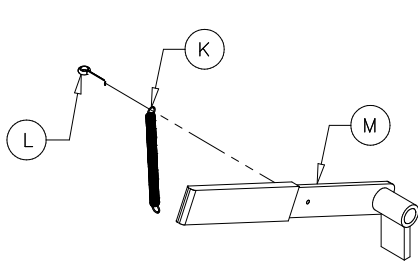

Figure 5 Optional

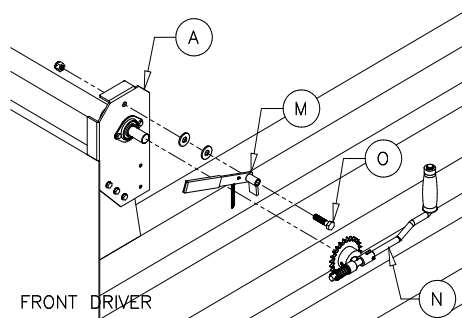

Figure 6 Optional

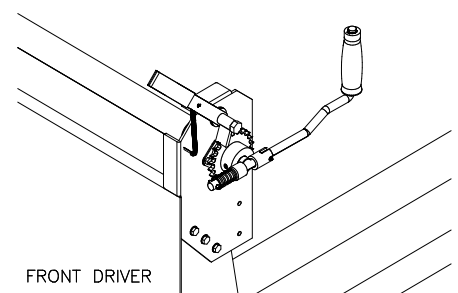

Figure 7 Optional

Step 5: Bottom Crank Installation
 (See Figure 8-10)

Procedure: Slide the 40X24 sprocket (P) and 1X hub on the roll-tube end (see Figure 8). Loosen the 3/4" bolt slightly so you can adjust the angle of the chain guard. Place the #40 roller chain (Q) on the 40X24 sprocket (P) (see Figure 9). Hang the bottom crank (R) from the #40 chain. Apply a downward force on the bottom crank (R) to stretch out the chain. Adjust the angle of the chain guard so the chain clears. Mark the slots of the bottom crank in the lower dump body. Tighten the 3/4" bolt with the chain guard is properly positioned. Using a 11/32" drill bit, drill four holes through the right sides of the bracket slots. Fasten the bottom crank to the box with the 3/8"x1-1/4" self-threading bolts (S) and 3/8" flat washers provided (see Figure 10). Further adjust the position of the #40X24 sprocket on the roll-tube end until it is aligned with the bottom crank (R). Remove the 5/16"x3/4" set screws from the 1X hub. Mark the location of the two 5/16" threaded holes in the 1X hub. Using a 5/16" drill bit, drill two holes in the roll-tube end approximately 1/4" deep. Secure the #40X24 sprocket and 1X hub to the roll-tube end with the 5/16"x3/4" set screws.

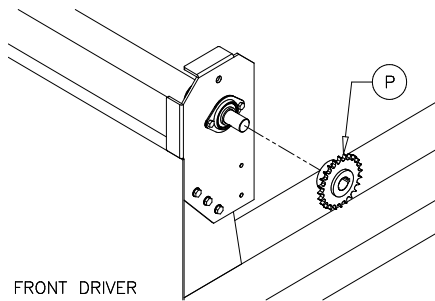

Figure 8

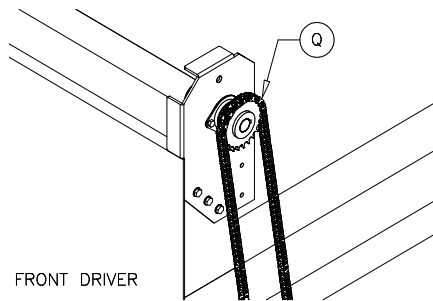

Figure 9

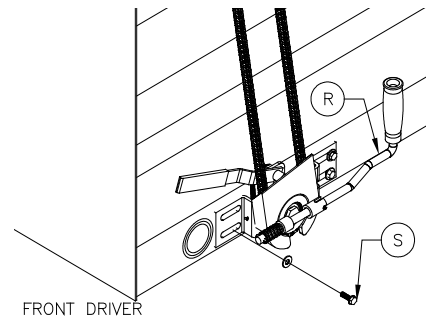

Figure 10

Step 6: Pivot Arm Installation
 (See Figure 11-20)

Procedure: Measure from Point A (see Figure 11) to a point on the lower inside rib of the box that is close to the pivot point (see Figure 12). Mark this point and record the distance as X. Using distance X, measure from Point B (see Figure 13), to a point on the lower inside rib of the box (see Figure 12). **Mark this point.** Divide the distance between the first and second mark by two and mark this point as the pivot point (see Figure 12).

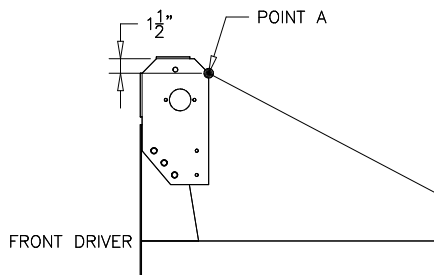

Figure 11

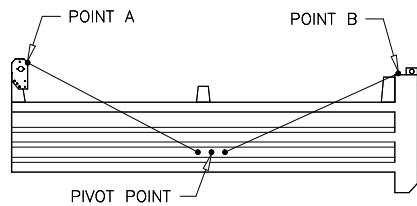

Figure 12

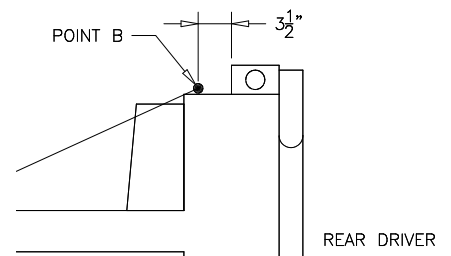

Figure 13

Align the pivot arm bracket (T) with the pivot point.

Note: The pivot arm end (U) must be aligned with the pivot point.

Step 6: Pivot Arm Installation Cont.

Using a 3/8" drill bit, drill through the center of the slots in the bracket (T) and through the box wall. Fasten the pivot arm bracket to the box with the 3/8"x1-1/2" hex bolt (V), 3/8" flat washers, and 3/8" nylon lock nuts provided (see Figure 14). Slide the helical torsion spring (B), bottom pivot arm (C), and 3/4" flat washer (D) on the pivot arm end (U). Insert and lock the cotter pin (E) (see Figure 15).

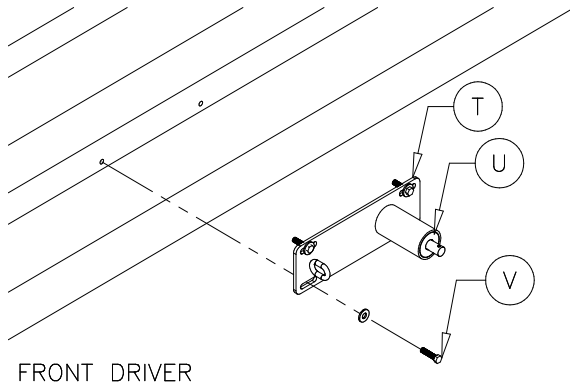

Figure 14

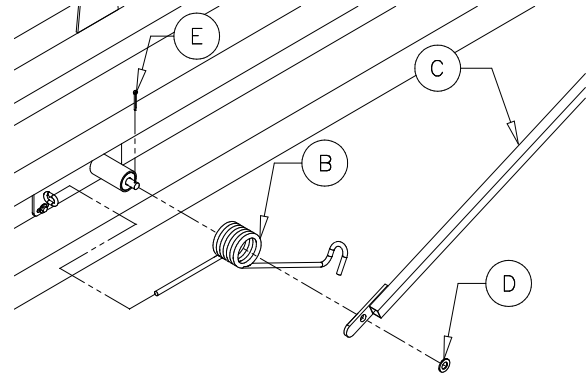

Figure 15

Note: The bottom pivot arm (C) may have to be shortened depending on the length of the box.

Position the bottom pivot arm (C) so it is hooked in the helical torsion spring (B) (see Figure 16). Repeat the above procedure for the opposite side of the box.

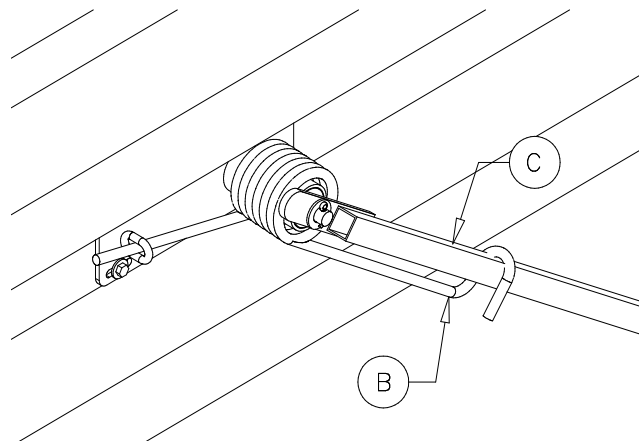

Figure 16

Slide the rear pivot arm cross-member (F) through the rear tarp pocket. Position the rear pivot arm cross-member at Point B (see Figure 13 & 17). Slide the top pivot arm (G) into the bottom pivot arm (C). Rotate the pivot arm towards the top of the box. Insert the 1" OD. pipe on the top pivot arm into the rear pivot arm cross-member (F). Repeat for the opposite side of the box.

Note: The 1"OD. pipe welded to the top pivot arm (C) may have to be shortened.

Adjust the rear pivot arm cross-member (F) and the top pivot arms (G) so they are at Point B (see Figure 13 & 17).

Step 6: Pivot Arm Installation Cont.

Note: Make sure that the distance the top pivot arm protrudes out of the bottom pivot arm is equal on both sides of the box.

Using a 5/16" drill bit, drill through the bottom and top pivot arm on both sides of the box. Secure the pivot arms with the 5/16"x1-3/4" hex bolt (H) and 5/16" nylon lock nut provided (see Figure 17). Adjust the pivot arms so they are aligned with the sides of the box. Rotate the rear pivot arm cross-member (F) so that the cross-member guides (I) are approximately 1/2" above the top of the box (see Figure 18). Using a 5/16" drill bit, drill through the pivot arm cross member (F) and top pivot arm (G). Secure the pivot arm cross-member to the top pivot arms with the 5/16"x1-3/4" hex bolts (H) and 5/16" nylon lock nuts provided (see Figure 19).

Note: Allow a great enough distance between the box wall and the pivot arm, in order to install the pivot arm guides on both sides of the box (see Step 7).

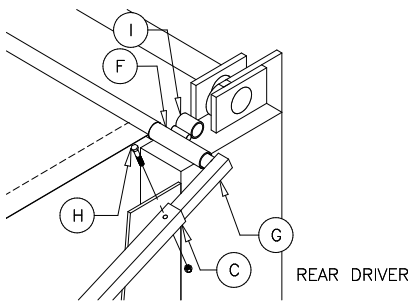

Figure 17

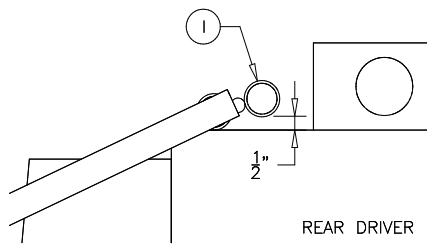

Figure 18

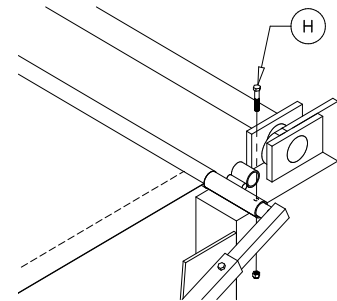

Figure 19

Center the rear tarp pocket on the rear pivot arm cross member (F). Position a PVC rear tarp clamp (J) on both edges of the tarp material. Fasten both tarp clamps to the tarp and rear pivot arm cross-member (F) with the #10-24x3-4 wafer head screws (K) provided (see Figure 20).

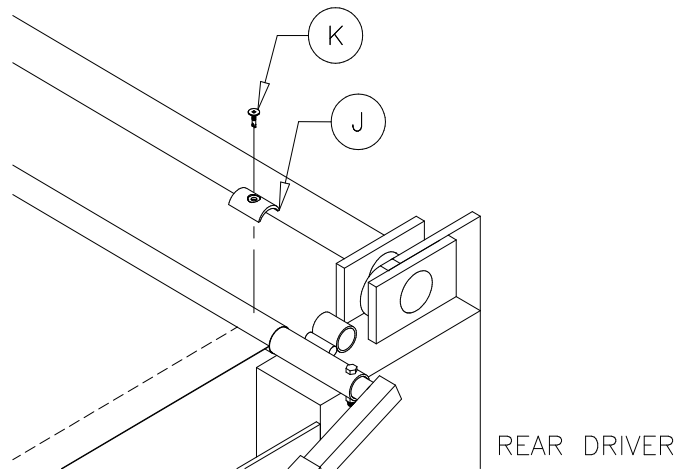

Figure 20

Step 7: Pivot Arm Guide Installation
 (See Figure 21-22)

Note: The pivot arm guides (L) (see Figure 21) prevent the tarp from shifting to either side of the box when the tarp is in the closed position.

Procedure: Close the tarp. Place a pivot arm guide (L) along one of the ribs in the box wall (see Figure 22). Make sure the guide is aligned with the pivot arm (C) (see Figure 22). Mark the position of the pivot arm guide. Using a 11/32" drill bit, drill two holes into the box wall. Secure the pivot arm guide to the box wall with the 3/8"x1-1/4" self-threading bolts provided.

Repeat the above procedure for the opposite side of the box.

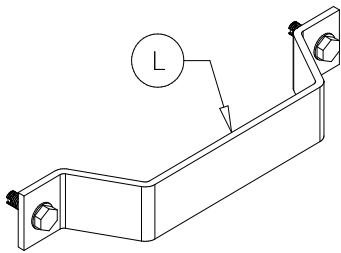

Figure 21

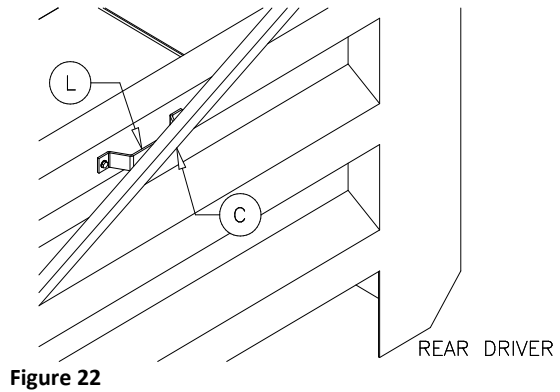

Figure 22

Step 8: Tarp Strap Installation (Optional)
 (See Figure 23-24)

Note: Tarp straps are only provided for the Econo Flip Tarp.

Procedure: Using a 1/4" drill bit, drill a hole through the top pivot arms to accept the tarp strap at the approximate location shown in Figure 23. Hook one end of the tarp strap in the 1/4" hole and stretch out the tarp strap. Mark the location of the tarp strap on the box. Drill a 1/4" hole into the box wall to accept the other end of the tarp strap (see Figure 24).

Repeat the above procedure for the other side of the box.

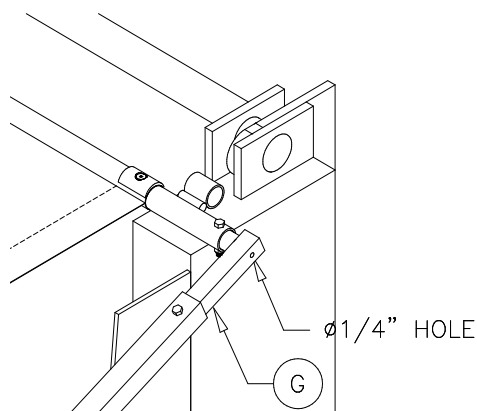

Figure 23

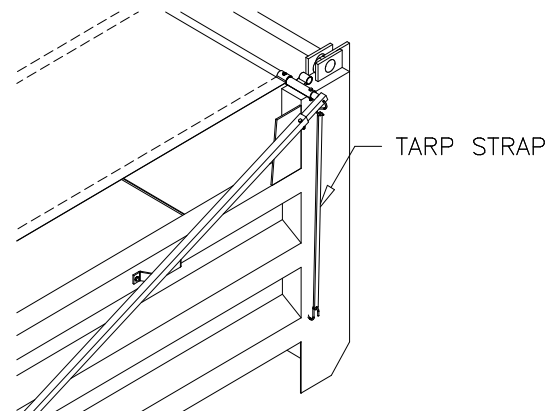

Figure 24

Warranty: Michel's Industries warrants their products for a period of one year from date of purchase. Any parts returned to Michel's Industries LTD. Will be shipped prepaid and will be returned F.O.B. St.Gregor, Sk. Canada. We will not assume responsibility for shipping, labor or travel expenses.

Note: We reserve the right to make improvements; therefore specifications are subject to change without notice.

Operating Instructions

Opening Tarp – To open the tarp, so it is fully rolled up on the front roll-tube to allow product to be dumped into the box, first unlock the rear lock if there is one installed. If installed, the tension should first be removed from the tarp by rotating the main crank clockwise. Then go to the rear of the trailer and remove the lynch pin holding the handle in the locked position. Rotate the handle up and use the lynch pin to secure the handle in the unlocked position. Go back to the front of the trailer and pull the handle of the crank and rotate it so the handle is sticking out from the box. Turn the crank counter clockwise to open the tarp. The locking handle on the crank will click on the sprocket and prevent the crank from spinning if you let go of the handle. Stop cranking when the tarp is completely rolled up on the front roll-tube. Reposition the crank handle back into transport position so it will not be sticking out (shown below).

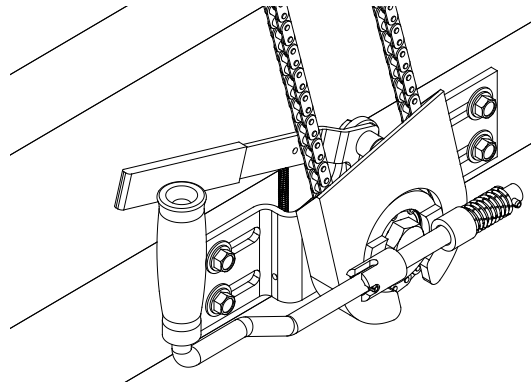

Closing Tarp – To cover your box, pull the crank handle and rotate it so the handle will be sticking out from the box. Firmly hold onto the crank handle and lift the locking handle up and slowly turn the crank clockwise to unroll the tarp. CAUTION The crank will want to spin clockwise on you since there is a high torque being applied to it. If you need to stop, lower the locking handle so it locks in the sprocket first and then let go of the handle. In case your hand slips off the crank handle, quickly let go of the locking handle and the tarp will stop. Unroll the tarp until the rear cross member is sitting on the back of the box. Once the rear cross-member is sitting on the top rail at the rear of the trailer, go to the rear and lock the tarp down if a lock is installed. If installed remove the lynch pin from the handle and rotate the handle downwards. This should cause the hooks to lock under the locking pins on the side of the box. Secure the handle in the locked position with the lynch pin. Go to the front and remove any slack in the tarp by cranking it counter clockwise.