

# Michel's FLIP TARP ELECTRIC - CHAIN DRIVE

## INSTALLATION INSTRUCTIONS

*PLEASE READ ENTIRE INSTRUCTIONS BEFORE BEGINNING*

### **Step 1: Electric Motor Installation**

*(See Figure 1-3)*

**Procedure:** Place the motor bracket against the front of the box by the rolltube bracket as in figure 1. Mark 4 of the holes on the box. Drill four 3/8" holes at your mark. Bolt the bracket to the box with the 3/8" bolts and nylon lock nuts provided. Place the motor in the bracket and secure with 5/16"x3/4"bolts and 5/16" lock washers. Figure 2. Slide the 40X24 sprocket and 1X hub assembly onto the roll-tube end (see Figure 2). Slide the 40X24 sprocket and 3/4" hub assembly onto the electric motor shaft with the key installed. Wrap the #40 roller chain around the sprockets to ensure that there is enough chain. If more chain is required then reposition the electric motor bracket accordingly. Remove the set screws from the 40X24 sprocket and 1X hub assembly. Align the sprocket and hub assemblies and mark the location of the set screw holes (see Figure 2). At the marked locations, using a 5/16" drill bit, drill into the roll-tube end approximately 1/4" deep. Tighten the set screws and install the roller chain (see Figure 2-3).

**Note:** To tighten the chain, loosen the 5/16"x3/4" hex bolts (see Figure 2) and adjust the electric motor.

Once chain is tight, place the cover on the bracket and secure using three 1/4"x1" lag screws. Secure into the steel tabs on the bracket.

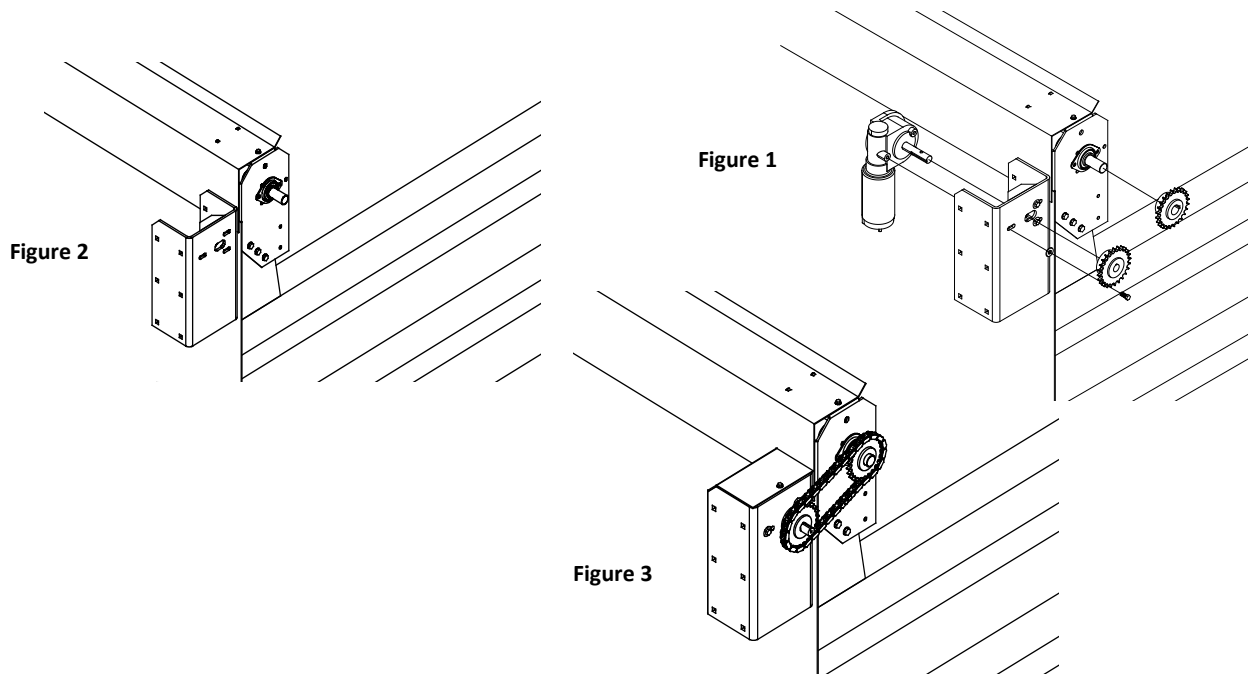

### **Step 2A: Rocker Switch Electrical Installation**

*(See Figure 4)*

**Note:** Apply the supplied Dielectric Lubricant to all wire connections when each wire is hooked up. The Dielectric Lubricant will help to prevent corrosion.

**Procedure:** Mount the 2 pole connector on the front of the trailer.

**Note:** If tarp is not going on a trailer, the 2 pole connector is not required. Run #6 double strand wire from the motor posts down the front, back to the hinge point of the box, and along the frame to the 2 pole connector. Secure the wire with the wire clips and lags provided. Install the motor cover on the motor and secure with two #10x1/2" screws. Mount the rocker switch in the dash or an obstruction free area in the truck cab. Mount the solenoid near the cab and the battery of the truck. Run #6 double strand wires from the solenoid along the truck frame to the 2 pole male connector at the back of the truck. Connect the motor wires to the "IN" & "OUT" on the solenoid. Install a black rubber boot on each wire. If not on a trailer, the #6 double strand wire would run straight from the motor to the solenoid. Run #6 double strand wire from the solenoid to the battery. Connect the positive (+) red wire to the positive(+) post on the solenoid alone with a red rubber boot and connect the negative (-) wire to the negative (-) post with a black rubber boot. Install a 50 amp circuit breaker in line with the positive wire. Run 14G-3 wire from the solenoid to the switch in the cab. The wires at the switch each get 14G female connectors crimped on. At the solenoid the 14G-3 wire gets two 14G female connectors and one 14G-1/4" ring terminal crimped on. The ring terminal is mounted on the battery positive (+) post of the solenoid.

**Note:** If the motor runs backwards, switch the two outside wires on the switch. Raise and lower the hoist to make sure that the wires are free from obstructions.

Figure 4

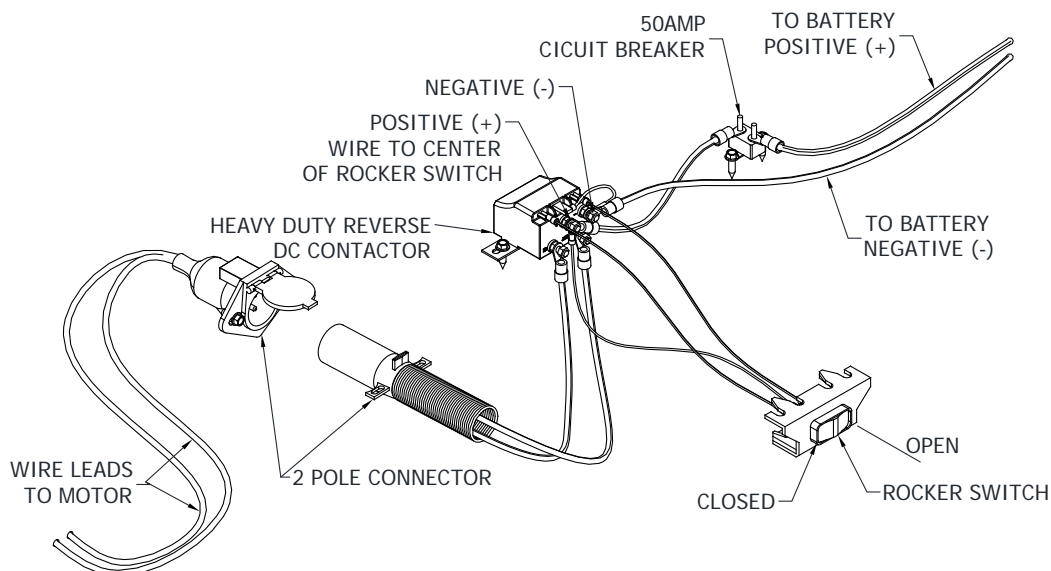

### Step 2B: Wireless Remote Electrical Installation

(See Figure 5)

#### Lead B-Train/Single Trailer Mounted Wireless Remote instructions

1. If the trailer is a closed front, drill a 2" hole in the front of the trailer and mount the supplied two pole female connector. If the trailer is an open front, mount the female connector on the top side of the frame.
2. Apply the supplied Dielectric Lubricant to all wire terminal connections as each wire is hooked up.
3. Mount the wireless remote box on the front of the trailer making sure that the switches will still be accessible.
4. Hook the red wire to the positive (+) post and the black wire to the negative (-) post on both the two pole connector and the remote box. Make sure to crimp, solder, and use the shrink tubes on the female trailer connector. Install the Red rubber boot on the positive wire at the remote box and a Black rubber boot on the negative wire.
5. Connect the wire to Motor 1 and 2 on the remote box and run the wire to the electric motor. Use the remaining two black rubber boots at the remote box.
6. Connect the black wire from negative (-) post of the battery directly onto the negative (-) terminal in the male trailer connector. Mount the 50A circuit breaker as close to the battery as possible. Connect the red wire from the positive

(+) post on the battery to the circuit breaker and from the circuit breaker to the positive (+) terminal in the male trailer connector. When installing the wires into the male trailer connector, the provided wire sleeves must be used on the end of the wires. It is required that the connection then be crimped, soldered, and the shrink sleeve installed. Double check that the positive and negative wires match the trailer plug. If these wires are crossed it will damage the wireless remote box.

7. Power the hand held remote on and press the open and close buttons to make sure that they work correctly. Also check the buttons on the remote box. If the motor runs the opposite direction as desired, reversed the wires that are connected to MOTOR 1 and 2.

### Rear B-Train Mounted Wireless Remote instructions

1. The two pole connector on the lead trailer is shared by the lead and rear trailer.
2. Run #6 wire from the two pole plug on the lead trailer to the rear of the lead trailer.
3. Wire the rear trailer the same as the above instructions for a single trailer.

### 3 Ton Truck Mounted Wireless Remote instructions

1. The instructions for a 3 Ton Truck are similar to the instruction for a trailer mounted Wireless Remote, with two exceptions.
  - a. Exclude the two pole connector and run the power wires direct from the battery and circuit breaker to the wireless remote box.
  - b. Mount the wireless remote box in a location where it won't be in the way and the buttons will be accessible

**Note:** If wiring is hooked up incorrectly it will void your warranty.

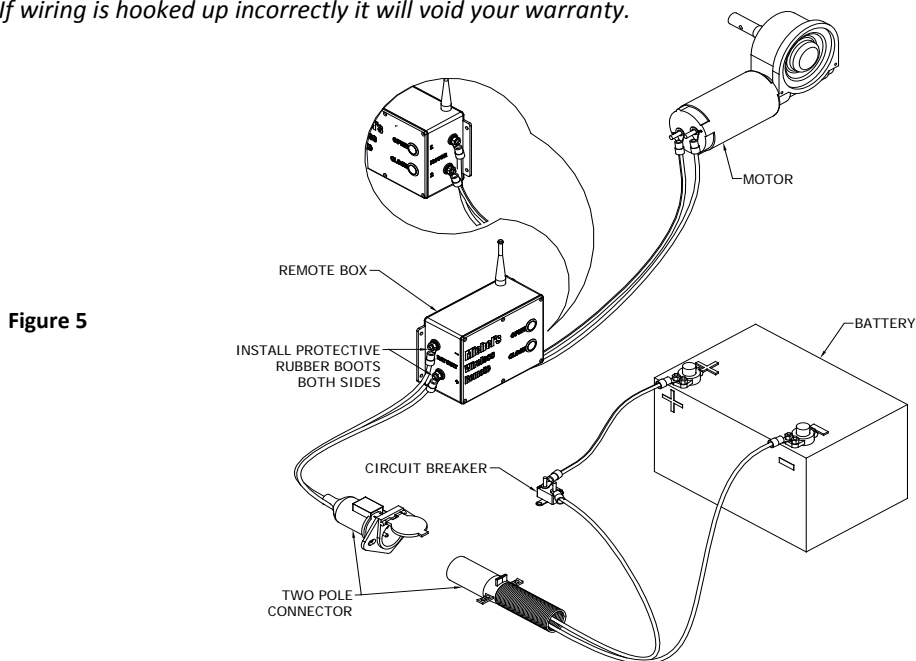

### Wireless Operation

Press and hold the power button on the transmitter until both LED's turn on, then release. The green LED will flash rapidly when communication has been established with receiver. The green LED flashes slowly if the receiver is off or there is no communication between the transmitter and receiver. Turn the receiver on and press the corresponding buttons on the transmitter keypad to turn on and off each of the outputs. **Only one receiver can be operated at a time.**